

A
STR
C
D
E
F
G
H
I
J
K
L
M
N
O
P

SECTION STR

STARTING SYSTEM

CONTENTS

<p>PRECAUTION 3</p> <p>PRECAUTIONS 3</p> <p style="padding-left: 20px;">Precaution for Supplemental Restraint System (SRS) "AIR BAG" and "SEAT BELT PRE-TENSIONER"3</p> <p>PREPARATION 4</p> <p>PREPARATION 4</p> <p style="padding-left: 20px;">Special Service Tools4</p> <p style="padding-left: 20px;">Commercial Service Tools4</p> <p>SYSTEM DESCRIPTION 5</p> <p>COMPONENT PARTS 5</p> <p>STARTING SYSTEM (WITH INTELLIGENT KEY).....5</p> <p style="padding-left: 20px;">STARTING SYSTEM (WITH INTELLIGENT KEY) : Component Parts Location5</p> <p style="padding-left: 20px;">STARTING SYSTEM (WITH INTELLIGENT KEY) : Component Description5</p> <p>STARTING SYSTEM (WITHOUT INTELLIGENT KEY)6</p> <p style="padding-left: 20px;">STARTING SYSTEM (WITHOUT INTELLIGENT KEY) : Component Parts Location6</p> <p style="padding-left: 20px;">STARTING SYSTEM (WITHOUT INTELLIGENT KEY) : Component Description6</p> <p>SYSTEM 8</p> <p>STARTING SYSTEM (WITH INTELLIGENT KEY).....8</p> <p style="padding-left: 20px;">STARTING SYSTEM (WITH INTELLIGENT KEY) : System Diagram8</p> <p style="padding-left: 20px;">STARTING SYSTEM (WITH INTELLIGENT KEY) : System Description8</p> <p>STARTING SYSTEM (WITHOUT INTELLIGENT KEY)8</p> <p style="padding-left: 20px;">STARTING SYSTEM (WITHOUT INTELLIGENT KEY) : System Diagram9</p>	<p>STARTING SYSTEM (WITHOUT INTELLIGENT KEY) : System Description 9</p> <p>WIRING DIAGRAM10</p> <p>STARTING SYSTEM (WITH INTELLIGENT KEY)10</p> <p style="padding-left: 20px;">Wiring Diagram (CVT Models)10</p> <p style="padding-left: 20px;">Wiring Diagram (M/T Models)11</p> <p>STARTING SYSTEM (WITHOUT INTELLIGENT KEY)12</p> <p style="padding-left: 20px;">Wiring Diagram (CVT Models)12</p> <p style="padding-left: 20px;">Wiring Diagram (M/T Models)13</p> <p>BASIC INSPECTION14</p> <p>DIAGNOSIS AND REPAIR WORK FLOW14</p> <p style="padding-left: 20px;">Work Flow (With GR8-1200 NI)14</p> <p style="padding-left: 20px;">Work Flow (Without GR8-1200 NI)17</p> <p>DTC/CIRCUIT DIAGNOSIS19</p> <p>B TERMINAL CIRCUIT19</p> <p style="padding-left: 20px;">Description19</p> <p style="padding-left: 20px;">Diagnosis Procedure19</p> <p>S TERMINAL CIRCUIT21</p> <p style="padding-left: 20px;">Description21</p> <p style="padding-left: 20px;">Diagnosis Procedure21</p> <p>SYMPTOM DIAGNOSIS22</p> <p>STARTING SYSTEM22</p> <p style="padding-left: 20px;">Symptom Table22</p> <p>REMOVAL AND INSTALLATION23</p> <p>STARTER MOTOR23</p> <p style="padding-left: 20px;">Exploded View23</p> <p style="padding-left: 20px;">Removal and Installation24</p>
---	---

SERVICE DATA AND SPECIFICATIONS
(SDS) 26

SERVICE DATA AND SPECIFICATIONS
(SDS) 26
 Starter Motor 26

PRECAUTIONS

< PRECAUTION >

PRECAUTION

PRECAUTIONS

Precaution for Supplemental Restraint System (SRS) "AIR BAG" and "SEAT BELT PRE-TENSIONER"

INFOID:000000008275908

The Supplemental Restraint System such as "AIR BAG" and "SEAT BELT PRE-TENSIONER", used along with a front seat belt, helps to reduce the risk or severity of injury to the driver and front passenger for certain types of collision. This system includes seat belt switch inputs and dual stage front air bag modules. The SRS system uses the seat belt switches to determine the front air bag deployment, and may only deploy one front air bag, depending on the severity of a collision and whether the front occupants are belted or unbelted. Information necessary to service the system safely is included in the "SRS AIR BAG" and "SEAT BELT" of this Service Manual.

WARNING:

Always observe the following items for preventing accidental activation.

- To avoid rendering the SRS inoperative, which could increase the risk of personal injury or death in the event of a collision that would result in air bag inflation, all maintenance must be performed by an authorized NISSAN/INFINITI dealer.
- Improper maintenance, including incorrect removal and installation of the SRS, can lead to personal injury caused by unintentional activation of the system. For removal of Spiral Cable and Air Bag Module, see "SRS AIR BAG".
- Never use electrical test equipment on any circuit related to the SRS unless instructed to in this Service Manual. SRS wiring harnesses can be identified by yellow and/or orange harnesses or harness connectors.

PRECAUTIONS WHEN USING POWER TOOLS (AIR OR ELECTRIC) AND HAMMERS

WARNING:

Always observe the following items for preventing accidental activation.

- When working near the Air Bag Diagnosis Sensor Unit or other Air Bag System sensors with the ignition ON or engine running, never use air or electric power tools or strike near the sensor(s) with a hammer. Heavy vibration could activate the sensor(s) and deploy the air bag(s), possibly causing serious injury.
- When using air or electric power tools or hammers, always switch the ignition OFF, disconnect the battery, and wait at least 3 minutes before performing any service.

A

STR

C

D

E

F

G

H

I

J

K

L

M

N

O

P

PREPARATION

< PREPARATION >

PREPARATION

PREPARATION

Special Service Tools

INFOID:000000008843418

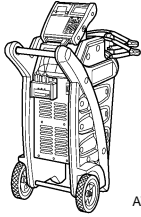
Tool number (Kent-Moore No.) Tool name	Description
<p>— (—) Model GR8-1200 NI Multitasking battery and electrical diagnostic station</p>  <p style="text-align: right; font-size: small;">AWIA1239ZZ</p>	<p>Tests batteries, starting and charging systems and charges batteries. For operating instructions, refer to diagnostic station instruction manual.</p>

Commercial Service Tools

INFOID:000000008275910

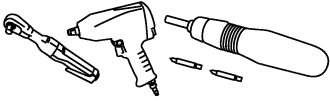
Tool name	Description
<p>Power tool</p>  <p style="text-align: right; font-size: small;">PIIB1407E</p>	<p>Loosening bolts, nuts and screws</p>

COMPONENT PARTS

< SYSTEM DESCRIPTION >

SYSTEM DESCRIPTION

COMPONENT PARTS

STARTING SYSTEM (WITH INTELLIGENT KEY)

STARTING SYSTEM (WITH INTELLIGENT KEY) : Component Parts Location

INFOID:000000008275911

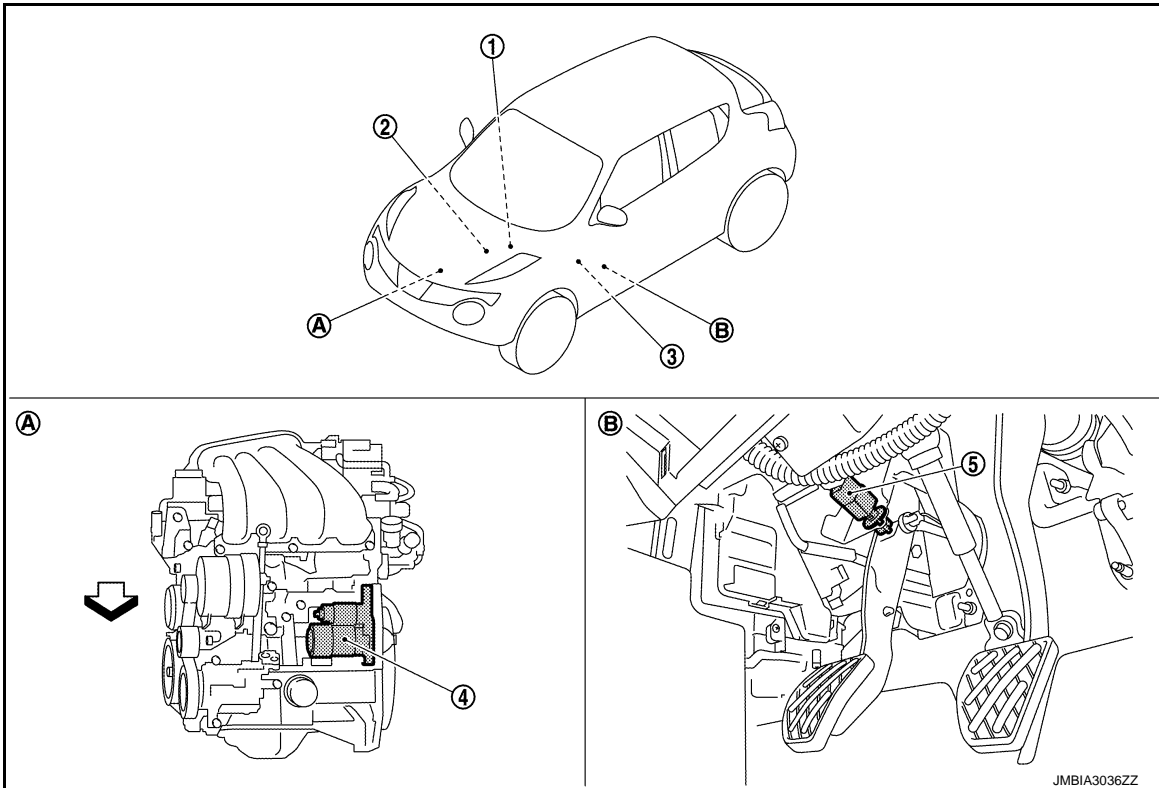

1. IPDM E/R
Refer to [PCS-5. "Component Parts Location"](#).
 2. Transmission range switch (CVT models)
Refer to [TM-69. "CVT CONTROL SYSTEM : Component Parts Location"](#).
 3. BCM
Refer to [BCS-6. "BODY CONTROL SYSTEM : Component Parts Location"](#).
 4. Starter motor
 5. Clutch interlock switch (M/T models)
- A. Engine
B. Clutch pedal (M/T models)

↶ :Vehicle front

STARTING SYSTEM (WITH INTELLIGENT KEY) : Component Description

INFOID:000000008275912

Component part	Description
BCM	BCM controls the starter relay.
IPDM E/R	CPU inside IPDM E/R controls the starter control relay.
Starter motor	The starter motor plunger closes and the motor is supplied with battery power, which in turn cranks the engine, when the "S" terminal is supplied with electric power.

COMPONENT PARTS

< SYSTEM DESCRIPTION >

Component part	Description
Transmission range switch (CVT models)	Transmission range switch supplies power to the starter relay and starter control relay inside IPDM E/R when the selector lever is shifted to the P or N position.
Clutch interlock switch (M/T models)	The switch turns ON and electric power is supplied to the starter relay and starter control relay inside IPDM E/R when the clutch pedal is depressed.

STARTING SYSTEM (WITHOUT INTELLIGENT KEY)

STARTING SYSTEM (WITHOUT INTELLIGENT KEY) : Component Parts Location

INFOID:000000008275913

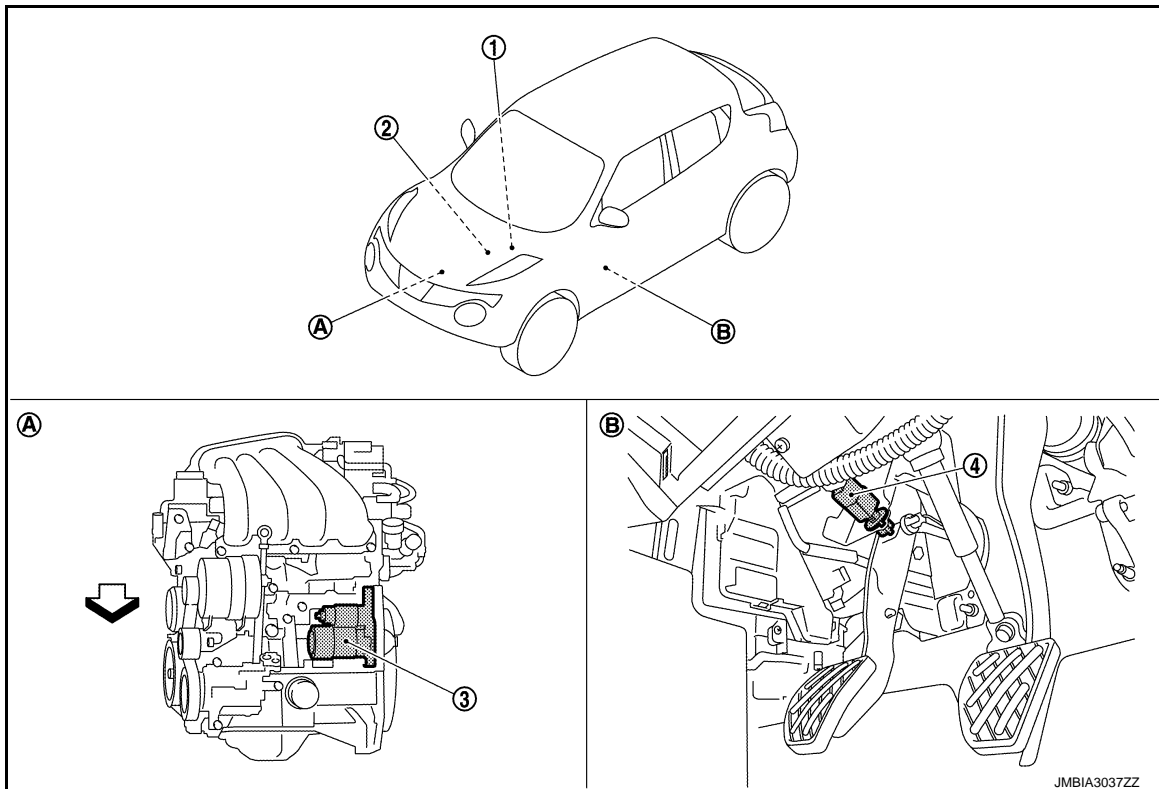

- 1. IPDM E/R
Refer to [PCS-38. "Component Parts Location"](#).
- 2. Transmission range switch (CVT models)
Refer to [TM-69. "CVT CONTROL SYSTEM : Component Parts Location"](#).
- 3. Starter motor
- 4. Clutch interlock switch (M/T models)
- A. Engine
- B. Clutch pedal (M/T models)

↶ :Vehicle front

STARTING SYSTEM (WITHOUT INTELLIGENT KEY) : Component Description

INFOID:000000008275914

Component part	Description
IPDM E/R	CPU inside IPDM E/R controls the starter control relay.
Starter motor	The starter motor plunger closes and the motor is supplied with battery power, which in turn cranks the engine, when the "S" terminal is supplied with electric power.

COMPONENT PARTS

< SYSTEM DESCRIPTION >

Component part	Description
Transmission range switch (CVT models)	Transmission range switch supplies power to the starter control relay inside IPDM E/R when the selector lever is shifted to the P or N position.
Clutch interlock switch (M/T models)	The switch turns ON and electric power is supplied to the starter control relay inside IPDM E/R when the clutch pedal is depressed.

A

STR

C

D

E

F

G

H

I

J

K

L

M

N

O

P

SYSTEM

< SYSTEM DESCRIPTION >

SYSTEM

STARTING SYSTEM (WITH INTELLIGENT KEY)

STARTING SYSTEM (WITH INTELLIGENT KEY) : System Diagram

INFOID:000000008275915

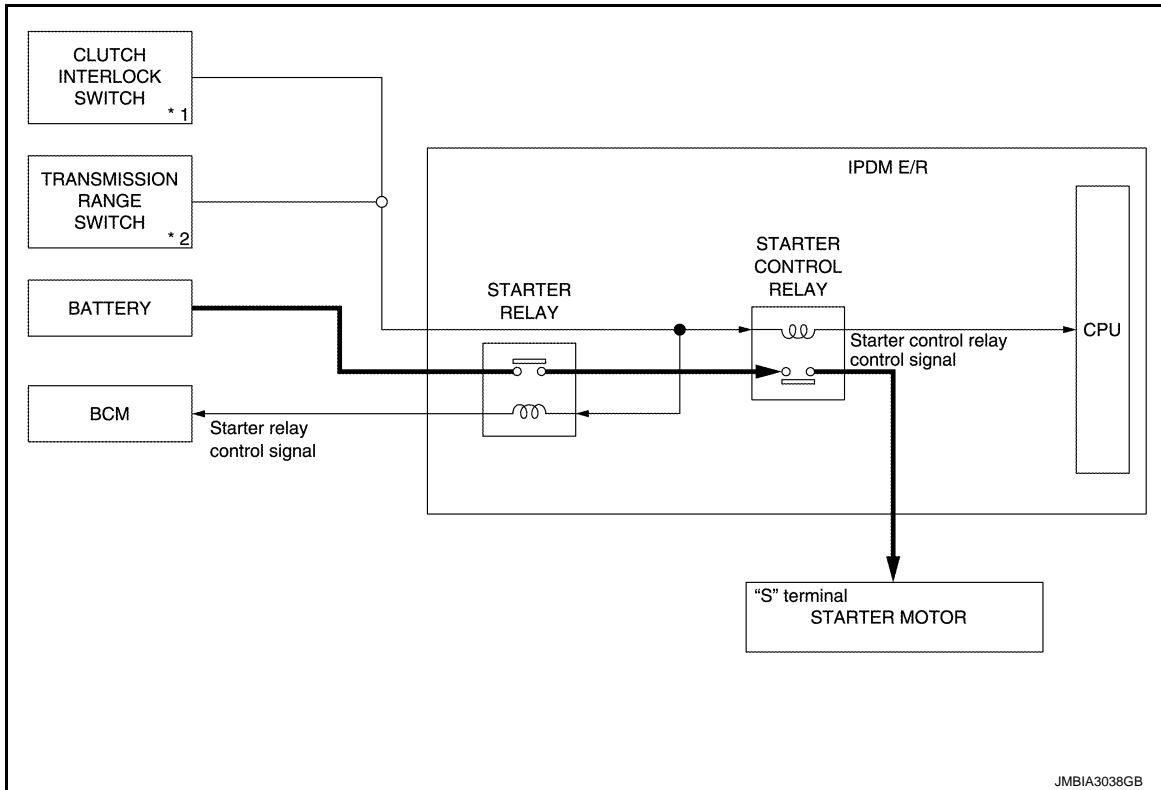

*1: M/T models

*2: CVT models

STARTING SYSTEM (WITH INTELLIGENT KEY) : System Description

INFOID:000000008275916

CVT MODELS

- When selector lever is P or N, power is supplied to starter relay and starter control relay by transmission range switch. And BCM and IPDM E/R (CPU) detect selector lever P/N condition by the inputted signal.
- When starter operating condition is satisfied, IPDM E/R turns starter control relay ON by starter control relay control signal.
- When engine cranking condition is satisfied, BCM turns starter relay ON by starter relay control signal.
- Then battery power is supplied to starter motor ("S" terminal) through starter control relay and starter relay.

M/T MODELS

- When the clutch interlock switch is turned ON position (clutch pedal is depressed) power is supplied to starter relay and starter control relay. And BCM and IPDM E/R (CPU) detect ignition switch position by the inputted signal.
- When starter operating condition is satisfied, IPDM E/R turns starter control relay ON by starter control relay control signal.
- When engine cranking condition is satisfied, BCM turns starter relay ON by starter relay control signal.
- Then battery power is supplied to starter motor ("S" terminal) through starter control relay and starter relay.

STARTING SYSTEM (WITHOUT INTELLIGENT KEY)

SYSTEM

< SYSTEM DESCRIPTION >

STARTING SYSTEM (WITHOUT INTELLIGENT KEY) : System Diagram

INFOID:000000008275917

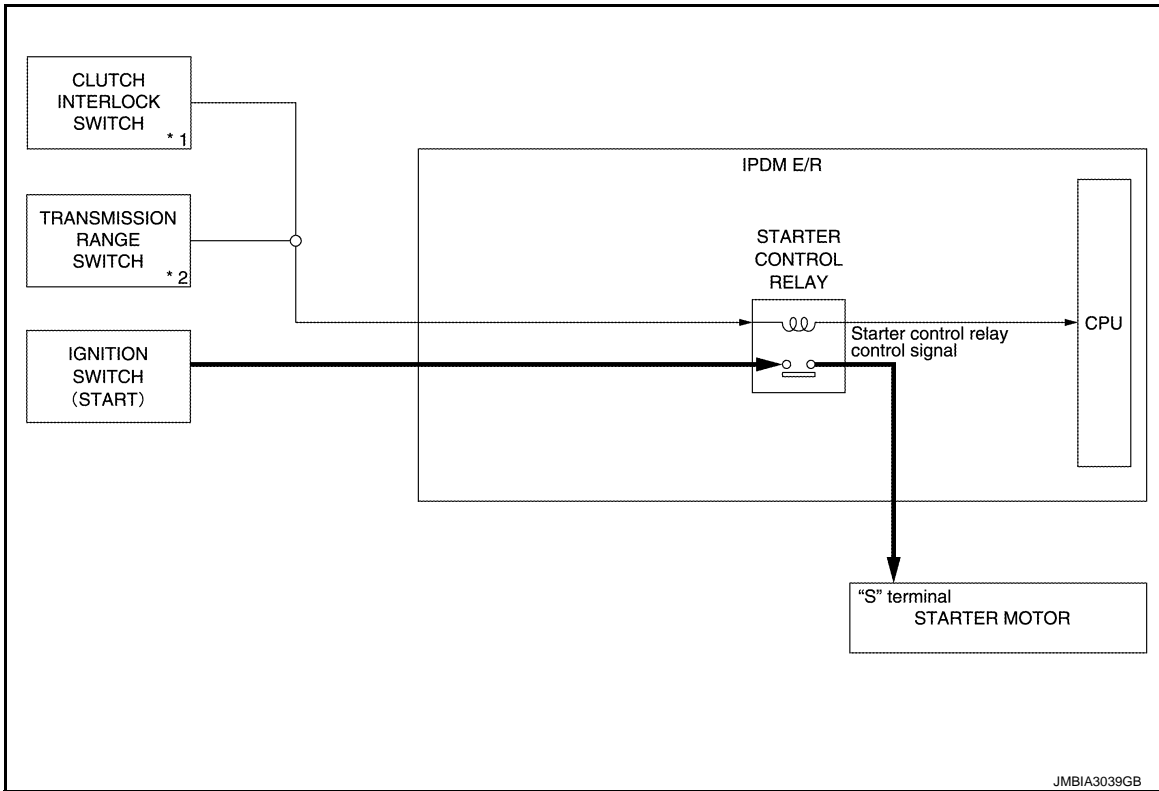

*1: M/T models

*2: CVT models

STARTING SYSTEM (WITHOUT INTELLIGENT KEY) : System Description

INFOID:000000008275918

CVT MODELS

- When selector lever is P or N, power is supplied to starter control relay by transmission range switch. And IPDM E/R (CPU) detect selector lever P/N condition by the inputted signal.
- When engine cranking condition is satisfied, then battery power is supplied to starter motor ("S" terminal) through starter control relay.

M/T MODELS

When the clutch pedal is depressed, battery power is supplied to starter motor ("S" terminal).

A

STR

C

D

E

F

G

H

I

STARTING SYSTEM (WITHOUT INTELLIGENT KEY) : System Description

INFOID:000000008275918

CVT MODELS

- When selector lever is P or N, power is supplied to starter control relay by transmission range switch. And IPDM E/R (CPU) detect selector lever P/N condition by the inputted signal.
- When engine cranking condition is satisfied, then battery power is supplied to starter motor ("S" terminal) through starter control relay.

M/T MODELS

When the clutch pedal is depressed, battery power is supplied to starter motor ("S" terminal).

J

K

L

M

N

O

P

STARTING SYSTEM (WITH INTELLIGENT KEY)

< WIRING DIAGRAM >

Wiring Diagram (M/T Models)

INFOID:000000008275920

For connector terminal arrangements, harness layouts, and alphabets in a  (option abbreviation; if not described in wiring diagram), refer to [GI-12, "Connector Information"](#).

STARTING SYSTEM (M/T WITH INTELLIGENT KEY)

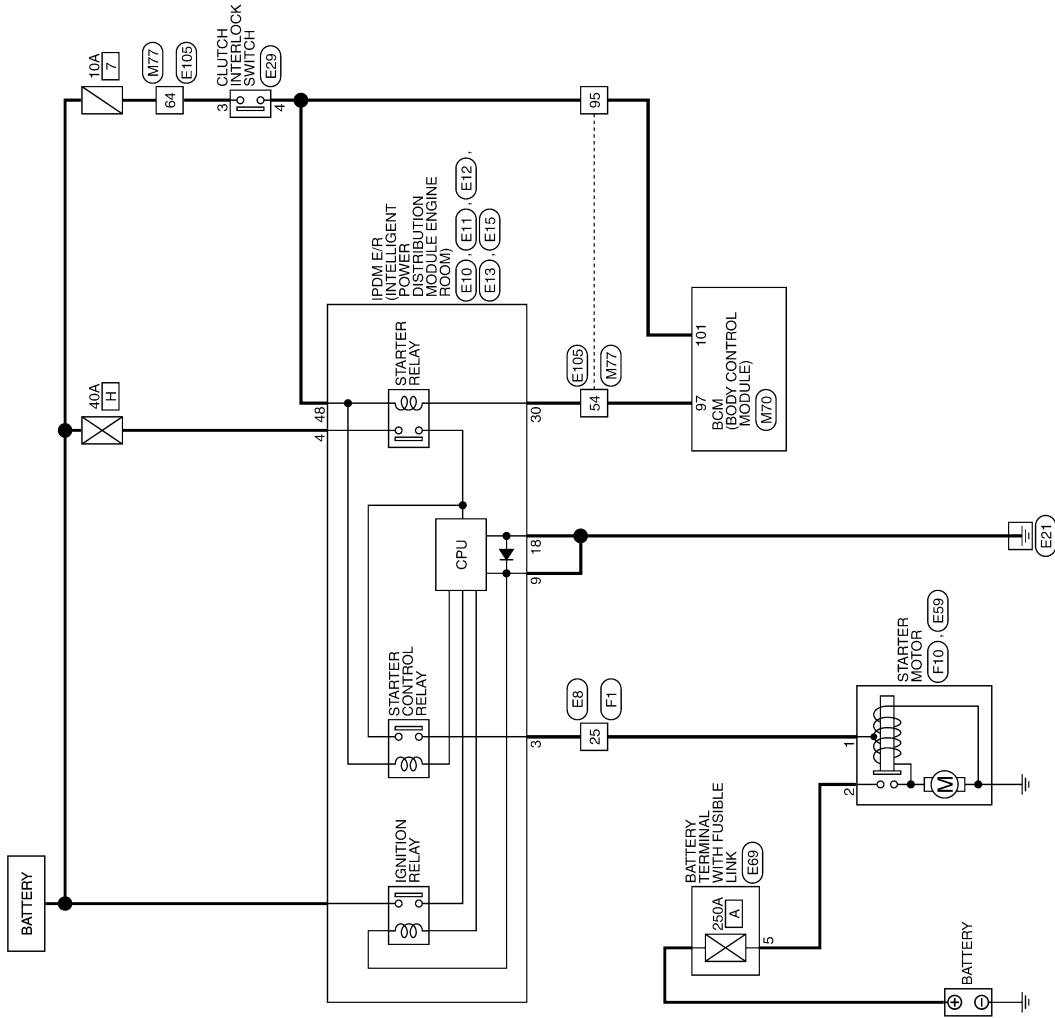

2011/08/18

JRBWC0741GB

A
STR
C
D
E
F
G
H
I
J
K
L
M
N
O
P

STARTING SYSTEM (WITHOUT INTELLIGENT KEY)

< WIRING DIAGRAM >

STARTING SYSTEM (WITHOUT INTELLIGENT KEY)

Wiring Diagram (CVT Models)

INFOID:000000008275921

For connector terminal arrangements, harness layouts, and alphabets in a  (option abbreviation; if not described in wiring diagram), refer to [GI-12, "Connector Information"](#).

STARTING SYSTEM (CVT WITHOUT INTELLIGENT KEY)

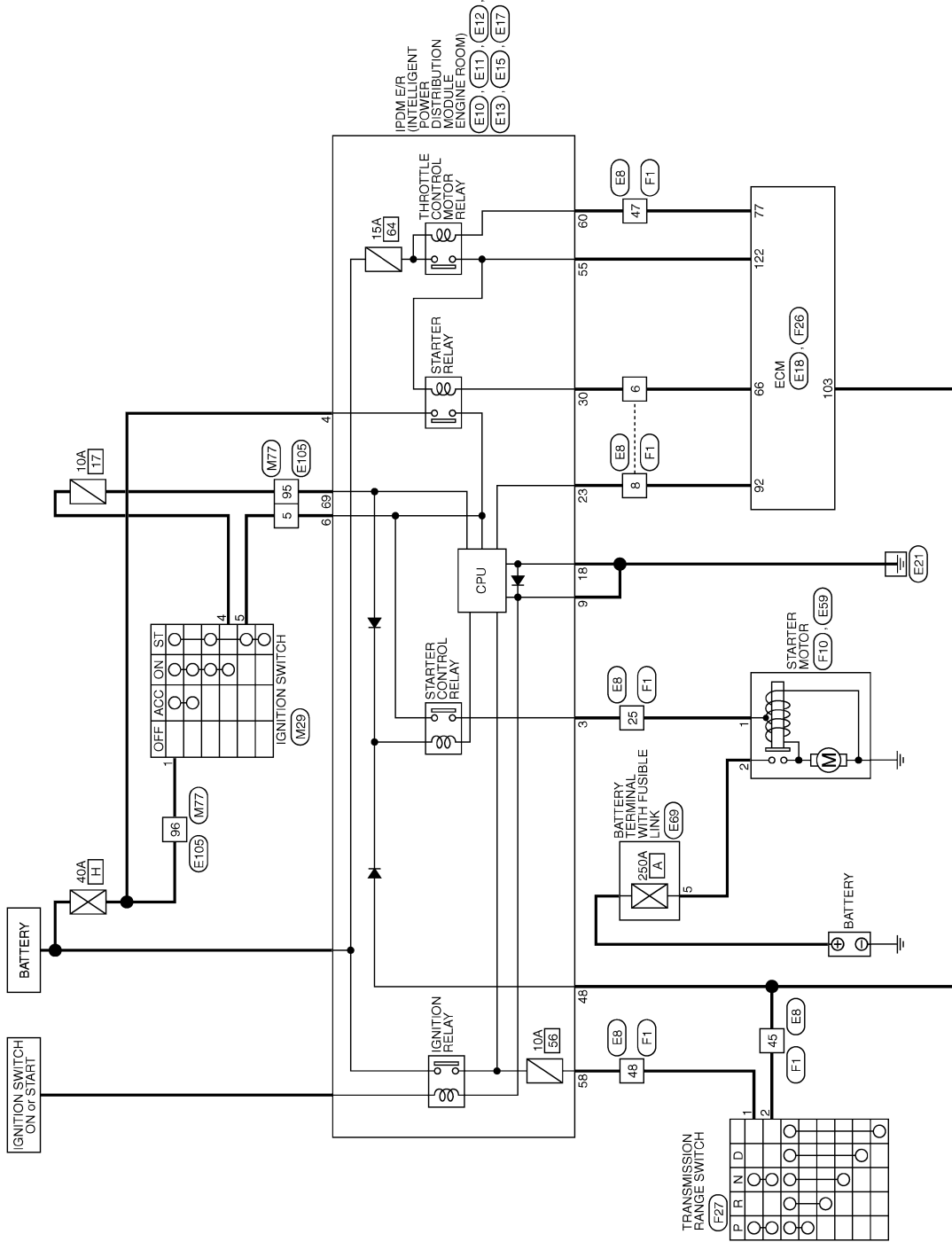

2010/08/30

JCBWA1811GB

STARTING SYSTEM (WITHOUT INTELLIGENT KEY)

< WIRING DIAGRAM >

Wiring Diagram (M/T Models)

INFOID:000000008275922

For connector terminal arrangements, harness layouts, and alphabets in a  (option abbreviation; if not described in wiring diagram), refer to [GI-12, "Connector Information"](#).

STARTING SYSTEM (M/T WITHOUT INTELLIGENT KEY)

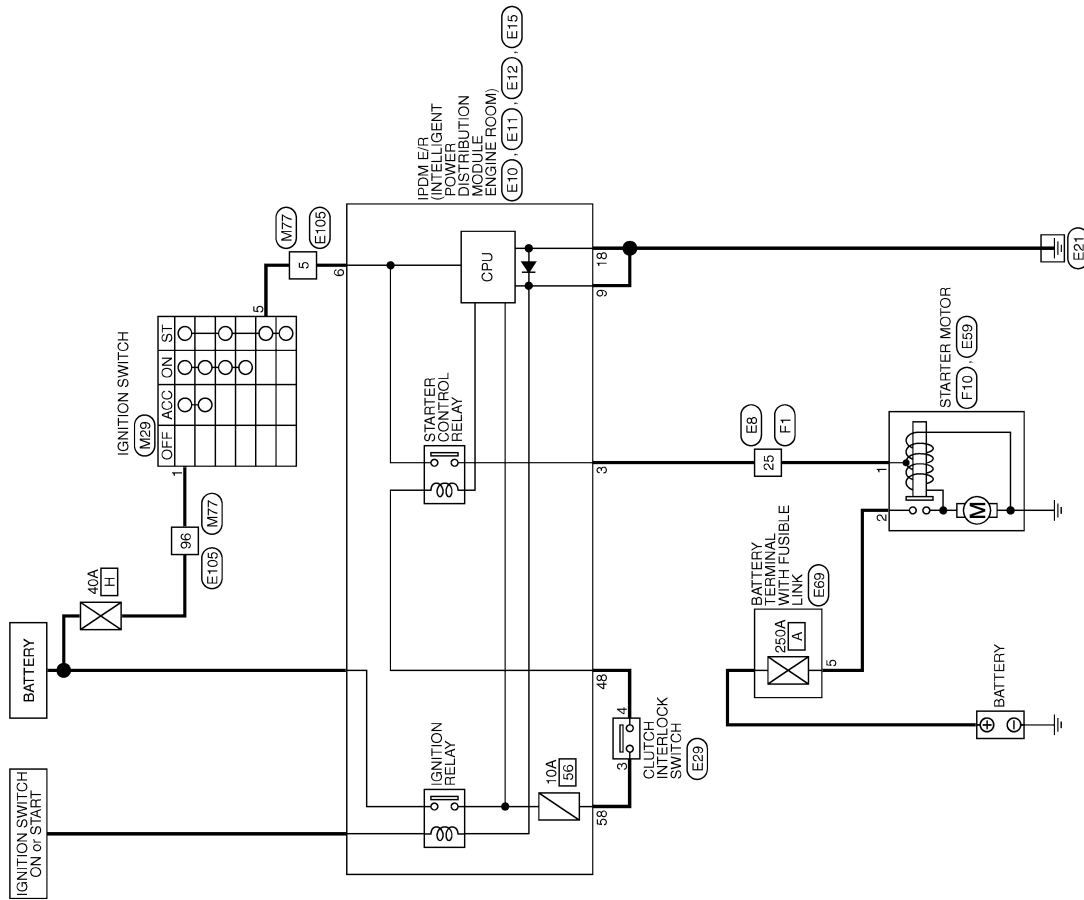

2010/08/30

JCBWA1816GB

A
STR
C
D
E
F
G
H
I
J
K
L
M
N
O
P

DIAGNOSIS AND REPAIR WORK FLOW

< BASIC INSPECTION >

BASIC INSPECTION

DIAGNOSIS AND REPAIR WORK FLOW

Work Flow (With GR8-1200 NI)

INFOID:000000008843420

STARTING SYSTEM DIAGNOSIS WITH GR8-1200 NI

To test the starting system, use the following special service tool:

- GR8-1200 NI Multitasking battery and electrical diagnostic station

NOTE:

Refer to the diagnostic station Instruction Manual for proper starting system diagnosis procedures.

DIAGNOSIS AND REPAIR WORK FLOW

< BASIC INSPECTION >

OVERALL SEQUENCE

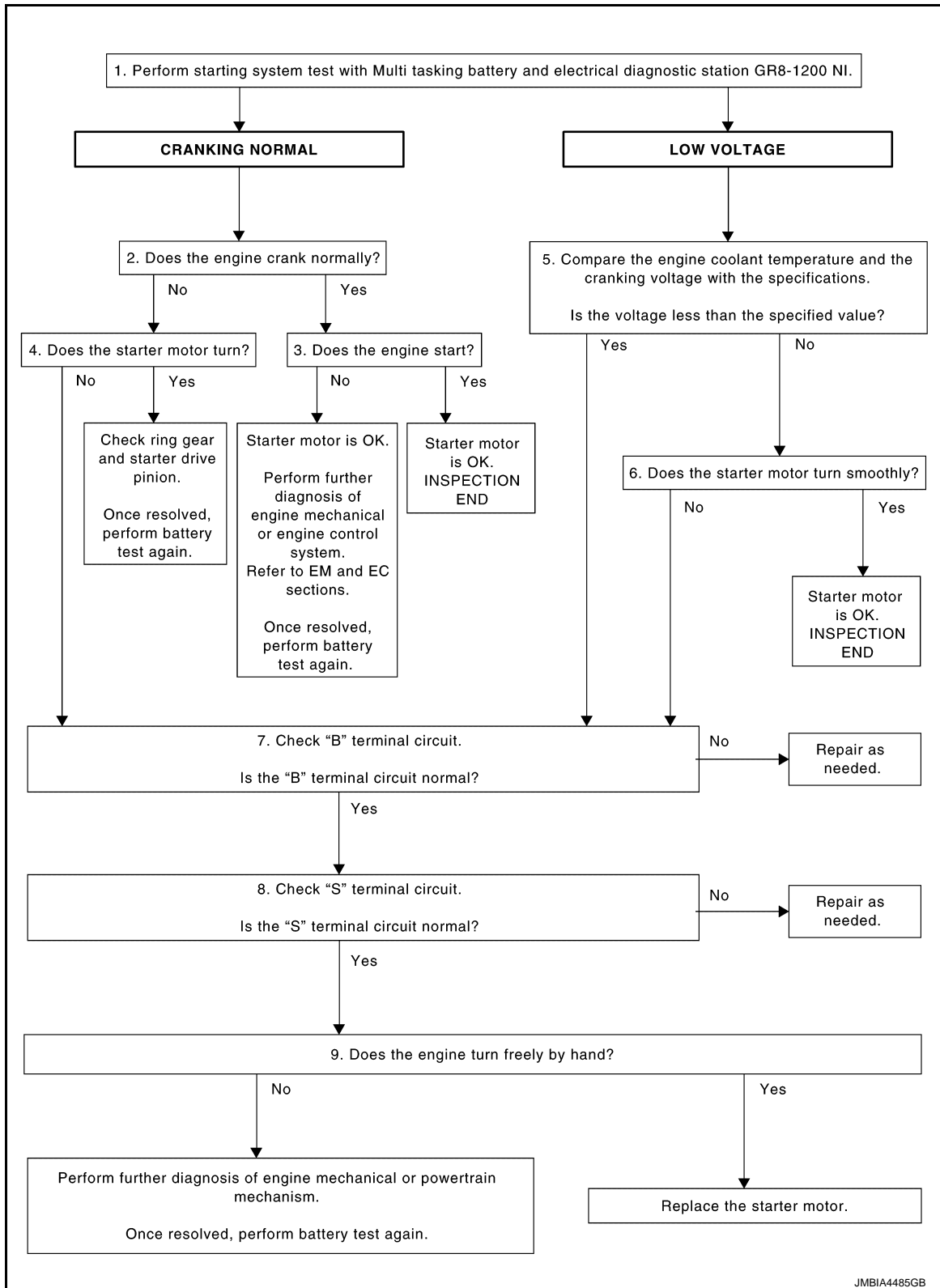

DETAILED FLOW

NOTE:

To ensure a complete and thorough diagnosis, the battery, starter motor and alternator test segments must be done as a set from start to finish.

1. DIAGNOSIS WITH MULTITASKING BATTERY AND ELECTRICAL DIAGNOSTIC STATION GR8-1200 NI

A

STR

C

D

E

F

G

H

I

J

K

L

M

N

O

P

JMBIA4485GB

DIAGNOSIS AND REPAIR WORK FLOW

< BASIC INSPECTION >

Perform the starting system test with Multitasking battery and electrical diagnostic station GR8-1200 NI. For details and operating instructions, refer to diagnostic station Instruction Manual.

Test result

CRANKING NORMAL>>GO TO 2.

LOW VOLTAGE>>GO TO 5.

CHARGE BATTERY>>Perform the slow battery charging procedure. (Initial rate of charge is 10A for 12 hours.) Perform battery test again. Refer to diagnostic station instruction manual.

REPLACE BATTERY>>Before replacing battery, clean the battery cable clamps and battery posts. Perform battery test again. Refer to diagnostic station instruction manual. If second test result is "REPLACE BATTERY", then do so. Perform battery test again to confirm repair.

2. CRANKING CHECK

Check that the starter motor operates correctly.

Does the engine crank normally?

YES >> GO TO 3.

NO >> GO TO 4.

3. ENGINE START CHECK

Check that the engine starts.

Does the engine start?

YES >> Starter motor is OK. INSPECTION END

NO >> Perform further diagnosis of engine mechanical or engine control system. Refer EM and EC sections. Once resolved, perform battery test again.

4. STARTER MOTOR ACTIVATION

Check that the starter motor operates.

Does the starter motor turn?

YES >> Check ring gear and starter motor drive pinion. Once resolved, perform battery test again.

NO >> GO TO 7.

5. COMPARISON BETWEEN ENGINE COOLANT AND CRANKING VOLTAGE

Compare the engine coolant temperature and the cranking voltage with the specifications.

Minimum Specification of Cranking Voltage Referencing Coolant Temperature

Engine coolant temperature [°C (°F)]	Voltage [V]
-30 to -20 (-22 to -4)	8.6
-19 to -10 (-2 to 14)	9.1
-9 to 0 (16 to 32)	9.5
More than 1 (More than 34)	9.9

Is the voltage less than the specified value?

YES >> GO TO 7.

NO >> GO TO 6.

6. STARTER OPERATION

Check the starter operation status.

Does the starter motor turn smoothly?

YES >> Starter motor is OK. INSPECTION END

NO >> GO TO 7.

7. "B" TERMINAL CIRCUIT INSPECTION

Check "B" terminal circuit. Refer to [STR-19, "Diagnosis Procedure"](#).

Is "B" terminal circuit normal?

YES >> GO TO 8.

NO >> Repair as needed.

8. "S" TERMINAL CIRCUIT INSPECTION

Check "S" terminal circuit. Refer to [STR-21, "Diagnosis Procedure"](#).

DIAGNOSIS AND REPAIR WORK FLOW

< BASIC INSPECTION >

Is "S" terminal circuit normal?

- YES >> GO TO 9.
- NO >> Repair as needed.

9. ENGINE ROTATION STATUS

Check that the engine can be rotated by hand.

Does the engine turn freely by hand?

- YES >> Replace starter motor. Refer to [STR-24. "Removal and Installation"](#).
- NO >> Perform further diagnosis of engine mechanical or powertrain mechanism. Once resolved, perform battery test again using Multitasking battery and electrical diagnostic station GR8-1200 NI. Refer to the diagnostic station Instruction Manual for proper testing procedures.

Work Flow (Without GR8-1200 NI)

INFOID:000000008843421

OVERALL SEQUENCE

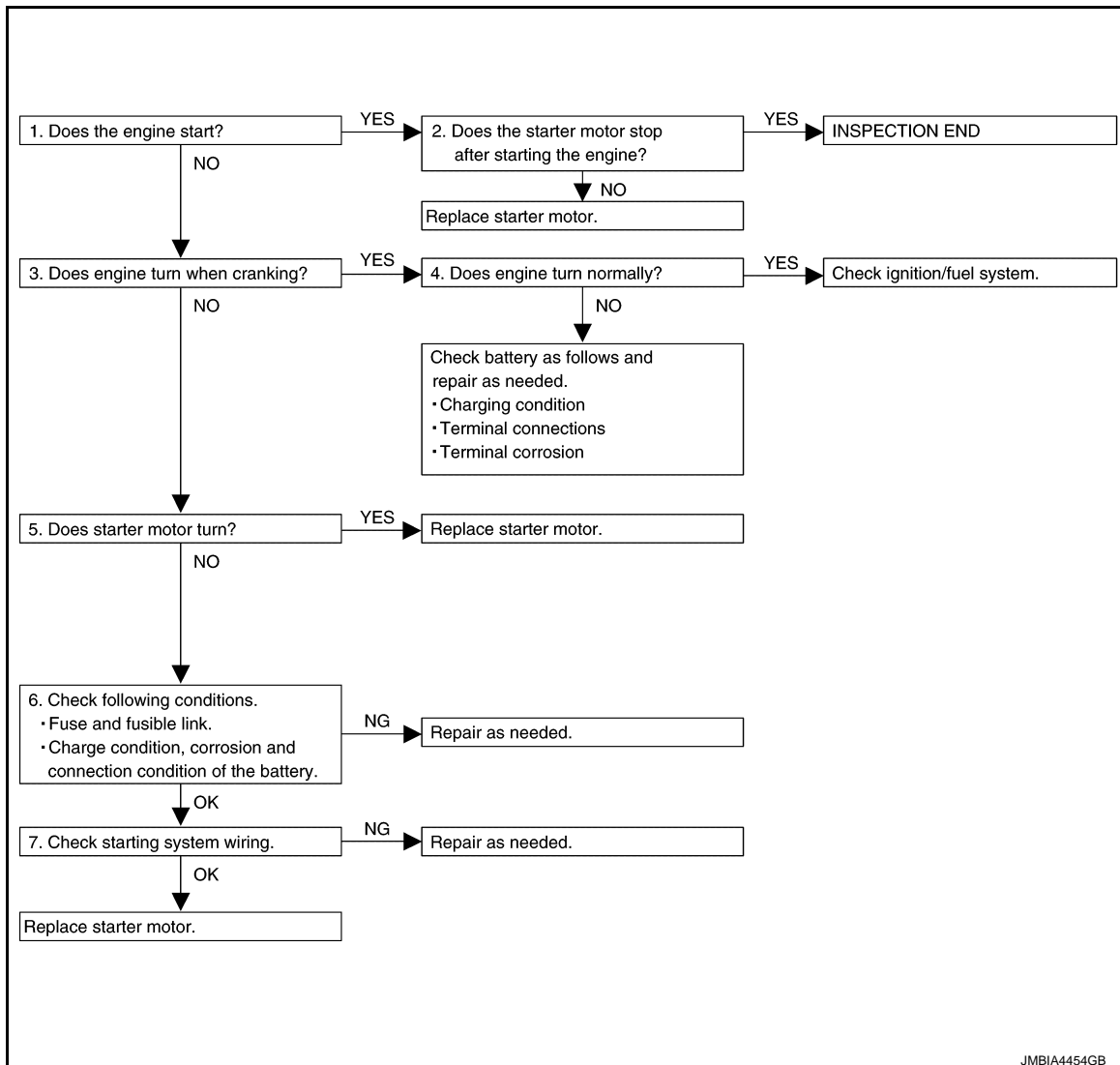

DETAILED FLOW

NOTE:

If any malfunction is found, immediately disconnect the battery cable from the negative terminal.

1. CHECK ENGINE START

Crank the engine and check that the engine starts.

Does the engine start?

- YES >> GO TO 2.

DIAGNOSIS AND REPAIR WORK FLOW

< BASIC INSPECTION >

NO >> GO TO 3.

2.CHECK THAT THE STARTER MOTOR STOPS

Check that the starter motor stops after starting the engine.

Does the starter motor stop?

YES >> INSPECTION END

NO >> Replace starter motor. Refer to [STR-24, "Removal and Installation"](#).

3.CHECK THAT THE ENGINE TURNS WHEN CRANKING

Check that the engine turns when cranking.

Does engine turn when cranking?

YES >> GO TO 4.

NO >> GO TO 5.

4.CHECK THE ENGINE SPEED WHEN CRANKING

Check that the engine speed is not low when cranking.

Does engine turn normally?

YES >> Check ignition/fuel system.

NO >> Check charge condition, corrosion and connection condition of the battery. Refer to [PG-88, "Work Flow"](#).

5.CHECK STARTER MOTOR ACTIVATION

Check that the starter motor runs at cranking.

Does starter motor turn?

YES >> Replace starter motor. Refer to [STR-24, "Removal and Installation"](#).

NO >> GO TO 6.

6.CHECK POWER SUPPLY CIRCUIT

Check the following conditions.

- Fuse and fusible link
- Charge condition, corrosion and connection condition of the battery. Refer to [PG-88, "Work Flow"](#).

Are these inspection results normal?

YES >> GO TO 7.

NO >> Repair as needed.

7.CHECK STARTING SYSTEM WIRING

Check the following.

- "B" terminal circuit. Refer to [STR-19, "Diagnosis Procedure"](#).
- "S" terminal circuit. Refer to [STR-21, "Diagnosis Procedure"](#).

Are these inspection results normal?

YES >> Replace starter motor. Refer to [STR-24, "Removal and Installation"](#).

NO >> Repair as needed.

B TERMINAL CIRCUIT

< DTC/CIRCUIT DIAGNOSIS >

DTC/CIRCUIT DIAGNOSIS

B TERMINAL CIRCUIT

Description

INFOID:000000008275924

STR

The "B" terminal is constantly supplied with battery power.

Diagnosis Procedure

INFOID:000000008275925

CAUTION:

Perform diagnosis under the condition that engine cannot start by the following procedure.

1. Remove fuel pump fuse.
2. Crank or start the engine (where possible) until the fuel pressure is released.

1.CHECK FUSIBLE LINK

Check that the following fusible link is not blown.

Terminal No.	Signal name	Fusible link No.
2	Battery power supply	A (250A)

Is the fusible link blown?

- YES >> Replace the blown fusible link after repairing the affected circuit if a fusible link is blown.
 NO >> GO TO 2.

2.CHECK "B" TERMINAL CIRCUIT

1. Turn ignition switch OFF.
2. Check that starter motor "B" terminal connection is clean and tight.
3. Check voltage between starter motor "B" terminal and ground.

Terminals			Voltage (Approx.)
(+)	(-)		
Starter motor "B" terminal	Terminal		Battery voltage
E59	2		

Is the inspection result normal?

- YES >> GO TO 3.
 NO >> Check harness between battery and starter motor for open circuit.

3.CHECK BATTERY CABLE CONNECTION STATUS (VOLTAGE DROP TEST)

1. Shift selector lever to "P" or "N" position. (CVT models)
Keep depressing clutch pedal fully. (M/T models)
2. Check voltage between battery positive terminal and starter motor "B" terminal.

Terminals			Condition	Voltage (Approx.)
(+)	(-)			
Battery positive terminal	Starter motor "B" terminal	Terminal	When the ignition switch is in START position	Less than 0.5 V
	E59	2		

Is the inspection result normal?

- YES >> GO TO 4.
 NO >> Check harness between the battery and the starter motor for poor continuity.

4.CHECK GROUND CIRCUIT STATUS (VOLTAGE DROP TEST)

1. Shift selector lever to "P" or "N" position. (CVT models)
Keep depressing clutch pedal fully. (M/T models)
2. Check voltage between starter motor case and battery negative terminal.

B TERMINAL CIRCUIT

< DTC/CIRCUIT DIAGNOSIS >

Terminals		Condition	Voltage (Approx.)
(+)	(-)		
Starter motor case	Battery negative terminal	When the ignition switch is in START position	Less than 0.2 V

Is the inspection result normal?

YES >> "B" terminal circuit is OK. Further inspection is necessary. Refer to [STR-14, "Work Flow \(With GR8-1200 NI\)"](#) or [STR-17, "Work Flow \(Without GR8-1200 NI\)"](#).

NO >> Check the starter motor case and ground for poor continuity.

S TERMINAL CIRCUIT

< DTC/CIRCUIT DIAGNOSIS >

S TERMINAL CIRCUIT

Description

INFOID:000000008275926

The starter motor magnetic switch is supplied with power when the ignition switch is turned to the START position while the selector lever is in the P or N position for CVT models or the clutch pedal is depressed for M/T models.

A

STR

Diagnosis Procedure

INFOID:000000008275927

CAUTION:

Perform diagnosis under the condition that engine cannot start by the following procedure.

1. Remove fuel pump fuse.
2. Crank or start the engine (where possible) until the fuel pressure is released.

D

1. CHECK "S" TERMINAL CIRCUIT

E

1. Turn ignition switch OFF.
2. Disconnect starter motor connector.
3. Shift selector lever to "P" or "N" position. (CVT models)
Keep depressing clutch pedal fully. (M/T models)
4. Check voltage between starter motor harness connector and ground.

F

Terminals		(-)	Condition	Voltage (Approx.)
(+)	Terminal			
Starter motor connector				
F10	1	Ground	When the ignition switch is in START position	Battery voltage

G

H

Is the inspection result normal?

I

YES >> "S" terminal circuit is OK. Further inspection is necessary. Refer to [STR-14, "Work Flow \(With GR8-1200 NI\)"](#) or [STR-17, "Work Flow \(Without GR8-1200 NI\)"](#).

J

NO >> GO TO 2.

2. CHECK HARNESS CONTINUITY (OPEN CIRCUIT)

1. Disconnect IPDM E/R connector.
2. Check continuity between starter motor harness connector and IPDM E/R harness connector.

K

Starter motor connector		IPDM E/R harness connector		Continuity
Connector No.	Terminal No.	Connector No.	Terminal No.	
F10	1	E10	3	Existed

L

Is the inspection result normal?

M

YES >> Further inspection is necessary. Refer to [STR-14, "Work Flow \(With GR8-1200 NI\)"](#) or [STR-17, "Work Flow \(Without GR8-1200 NI\)"](#).

N

NO >> Repair the harness.

O

P

STARTING SYSTEM

< SYMPTOM DIAGNOSIS >

SYMPTOM DIAGNOSIS

STARTING SYSTEM

Symptom Table

INFOID:000000008275928

Symptom	Reference
No normal cranking	Refer to STR-14, "Work Flow (With GR8-1200 NI)" or STR-17, "Work Flow (Without GR8-1200 NI)" .
Starter motor does not rotate	

STARTER MOTOR

< REMOVAL AND INSTALLATION >

REMOVAL AND INSTALLATION

STARTER MOTOR

Exploded View

INFOID:000000008275929

A

STR

REMOVAL

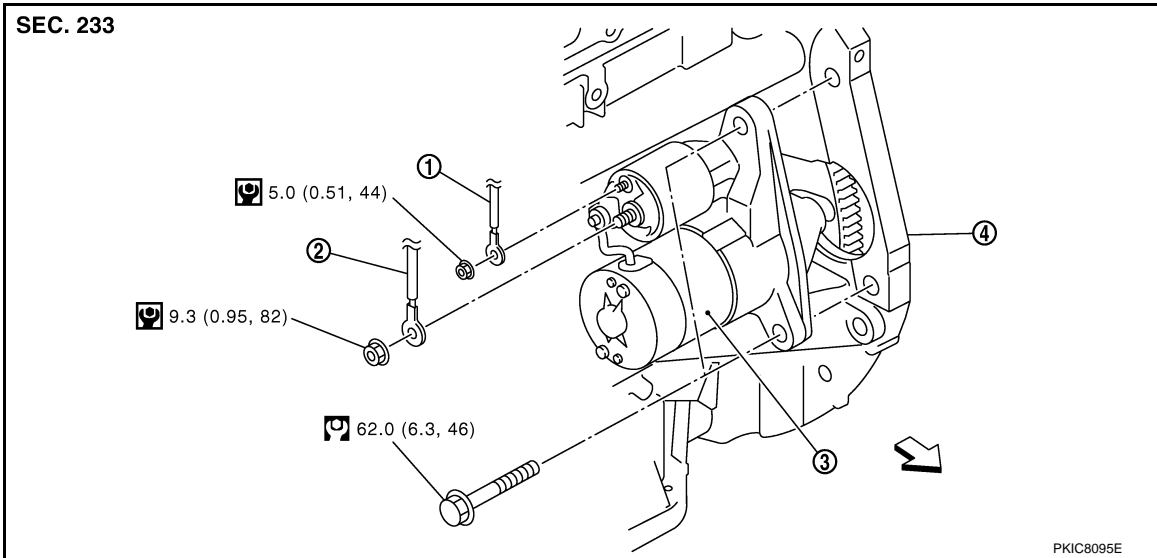

1. "S" terminal harness

2. "B" terminal harness

3. Starter motor

4. Cylinder block

↔ : Vehicle front

🔧 : N·m (kg-m, ft-lb)

🔧 : N·m (kg-m, in-lb)

DISASSEMBLY

C

D

E

F

G

H

I

J

K

L

M

N

O

P

STARTER MOTOR

< REMOVAL AND INSTALLATION >

Type: S114-955

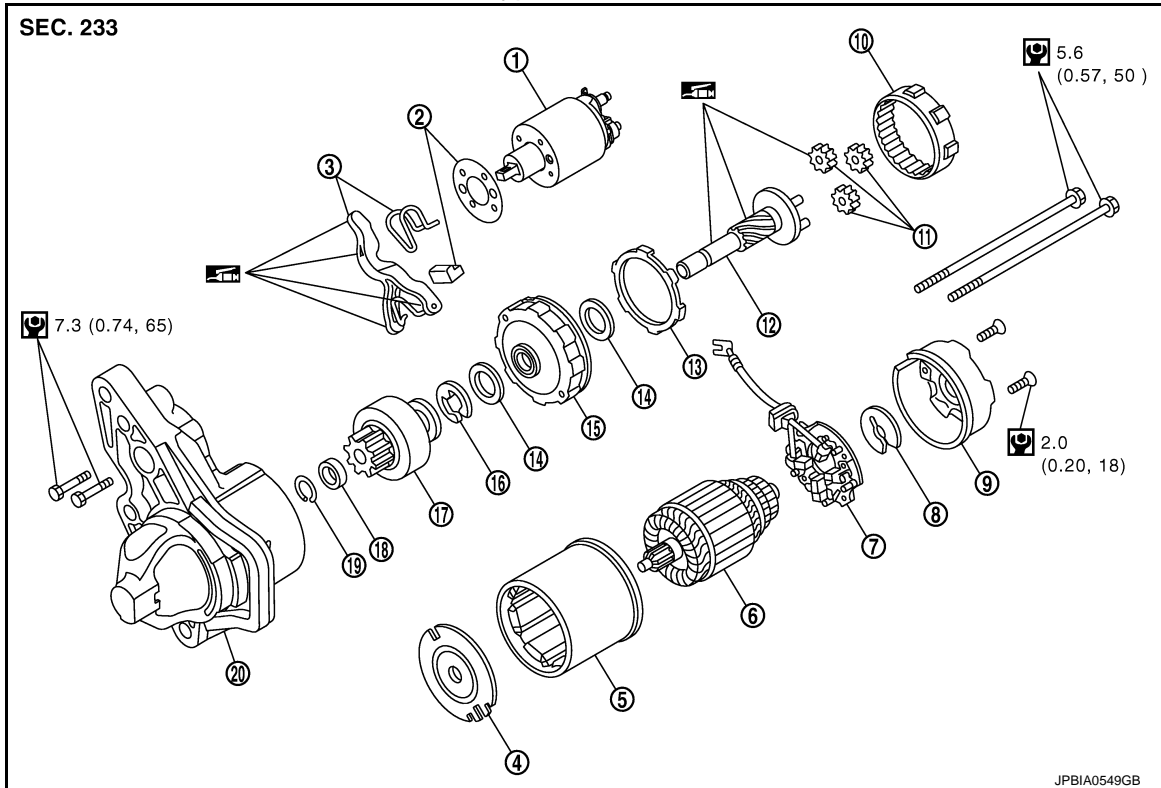

- | | | |
|-----------------------------|------------------------|------------------------|
| 1. Magnetic switch assembly | 2. Dust cover kit | 3. Shift lever set |
| 4. Center bracket (A) | 5. Yoke assembly | 6. Armature assembly |
| 7. Brush holder assembly | 8. Thrust washer | 9. Rear cover assembly |
| 10. Internal gear | 11. Planetary gear | 12. Pinion shaft |
| 13. Packing | 14. Thrust washer | 15. Center bracket (P) |
| 16. E-ring | 17. Pinion assembly | 18. Pinion stopper |
| 19. Pinion stopper clip | 20. Gear case assembly | |

 : High-temperature grease point

 : N·m (kg·m, in·lb)

NOTE:

Apply high-temperature grease to lubricate the bearing, gears and frictional surface when assembling the starter.

Removal and Installation

INFOID:000000008275930

REMOVAL

1. Disconnect the battery cable from the negative terminal. Refer to [PG-96, "Removal and Installation"](#).
2. Drain engine coolant from radiator. Refer to [CO-8, "Draining"](#).
3. Remove charge air cooler. Refer to [EM-30, "Removal and Installation"](#).
4. Remove CVT water hose on thermostat housing side (CVT models). Refer to [CO-22, "Exploded View"](#).
5. Remove radiator hose (lower) on water inlet side. Refer to [CO-14, "Removal and Installation"](#).
6. Move CVT water hose A and radiator hose (lower) to a location where they do not inhibit work.

STARTER MOTOR

< REMOVAL AND INSTALLATION >

7. Open "B" terminal cover, in the direction indicated by an arrow, as shown in the figure.

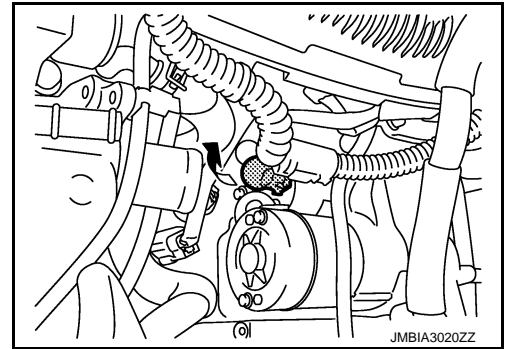

8. Remove "B" terminal nut and "B" terminal harness.
9. Remove "S" terminal nut and "S" terminal harness.
10. Disconnect harness connector (1) from crankshaft position sensor.
11. Remove harness fixing clip (A) from oil pan (upper), and then move harness (2) to a location where they do not inhibit work.

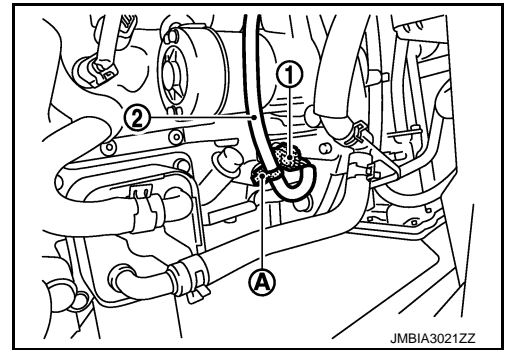

12. Remove starter motor mounting bolts.
13. Remove starter motor forward from the vehicle.

INSTALLATION

Note the following items, and install in the reverse order of removal.

CAUTION:

- Be careful to tighten "B" terminal nut to the specified torque.
- After work is complete fill engine coolant. Refer to [CO-9. "Refilling"](#).

A

STR

C

D

E

F

G

H

I

J

K

L

M

N

O

P

SERVICE DATA AND SPECIFICATIONS (SDS)

< SERVICE DATA AND SPECIFICATIONS (SDS)

SERVICE DATA AND SPECIFICATIONS (SDS)

SERVICE DATA AND SPECIFICATIONS (SDS)

Starter Motor

INFOID:000000008275932

Type		S114 - 955
		HITACHI make
		Reduction gear type
System voltage		[V] 12
No-load	Terminal voltage	[V] 11
	Current	[A] Less than 110
	Revolution	[rpm] More than 3000