

Ignition System: Delco EST

Contents

Models: 3.0 GL/GS, 4.3 GL, 5.0GL-B/C/D/E, 5.7GL-B/C/D/E	54
Ignition System Troubleshooting	54
12 Volt Positive (B+) Test	54
Ignition Coil Test	55
Pickup Coil Test	55
Ignition Module Test	56
Distributor Removal	56
Distributor Service	57
Disassembly	57
Reassembly	57
Distributor Installation	58
Timing Out of Synch	59
Setting Initial Timing	60
Ignition Coil Replacement	61
Ignition System Problems	63
Specifications	64
Ignition Timing Advance	64
Ignition Components	64
Ignition Circuit	65
Models: 3.0 GS-A/B/C, 3.0GL-A/B, 4.3 GLA/B/C, 5.0GL-B/C/D, 5.7GL-B/C/D	65
Models: 3.0 GL-C, 4.3GL-D, 5.0GL-E, 5.7GL-E	66

Models: 3.0 GL/GS, 4.3 GL, 5.0GL-B/C/D/E, 5.7GL-B/C/D/E

Description

The Delco EST (Electronic Spark Timing) system is used on non-EFI engines. The system consists of a distributor with an electronic ignition control module and pickup coil, a cap, rotor and remote coil. It does not contain breaker points, a condenser or centrifugal advance.

Ignition System Troubleshooting

The following tests are used to check various components of the Delco system. These tests should be conducted as necessary to solve a particular problem, and should not be part of a normal tune-up procedure. The following equipment will be needed:

- Ohmmeter
- Voltmeter
- Terminal Adaptors
- Timing Light
- Timing Test Lead
Volvo Penta P/N 885163-6
- Tachometer

NOTE! All running tests must be conducted in water with the correct test propeller to properly load engine. Do not perform tests with a flushing adaptor.

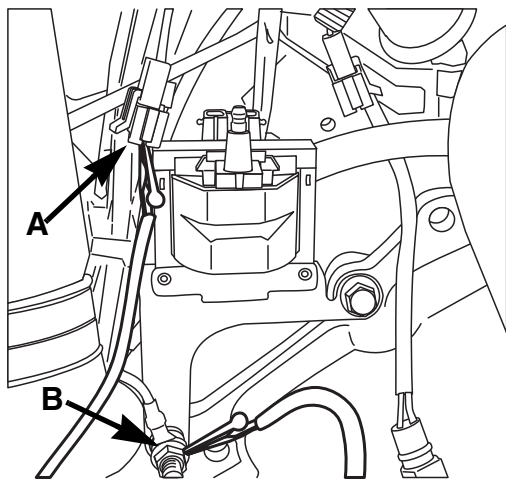

23103

2. Connect voltmeter positive (+) lead to purple wire terminal **A** in connector and the negative (-) lead to engine ground **B**. Turn on ignition switch, meter should read a minimum of 8 volts.

Distributor:

1. Attach purple and gray wire connector to coil. Disconnect pink and brown wire connector at distributor.
2. Connect voltmeter positive (+) lead to pink wire terminal **C** in connector and the negative (-) lead to engine ground. Turn on ignition switch, meter should read a minimum of 8 volts.

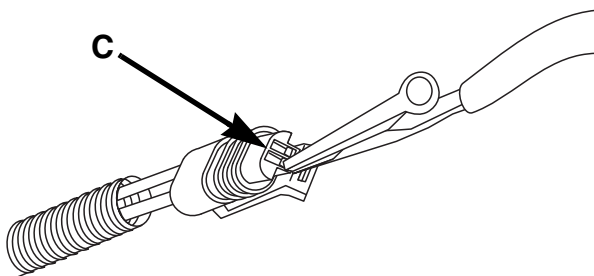

23104

12 Volt Positive (B+) Test

Ignition Coil:

1. Disconnect the purple and gray wire connector at coil.

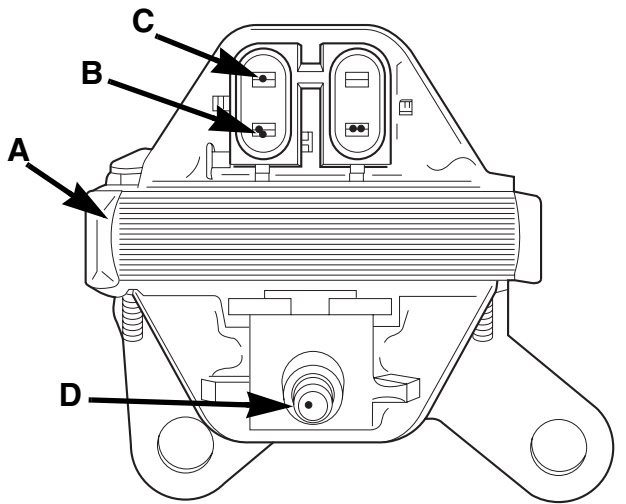

23110

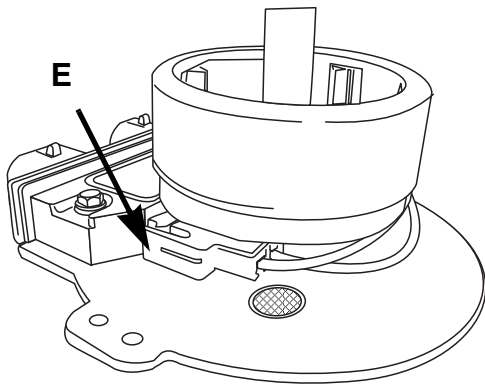

23111

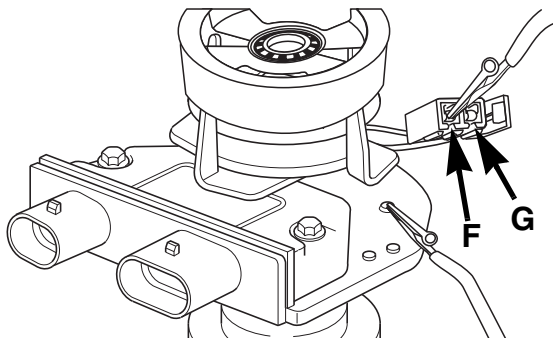

23108

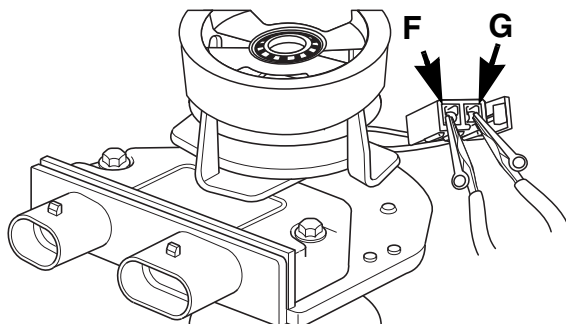

23113

Ignition Coil Test

The ignition coil can be checked for open circuits and shorts with an ohmmeter. If the ignition coil fails any one of the following checks, replace it. **Remove both wire connectors from coil before performing tests.**

1. To check for short to ground, connect ohmmeter to the frame **A** and purple wire terminal **B**. With the ohmmeter set on the high scale, reading should be infinite (∞). A reading of other than infinity (∞) indicates a short to ground.
2. To check for an open or shorted primary circuit, connect ohmmeter to purple wire terminal **B** and gray wire terminal **C**. With the ohmmeter set on the low scale, reading should be .35-.45 ohms. A reading of more than .45 ohms indicates a possible open circuit. A reading of less than .35 ohms indicates a shorted circuit.
3. To check for an open or shorted secondary circuit, connect ohmmeter to purple wire terminal **B** and high tension terminal **D**. With the ohmmeter set on the high scale, reading should be 7500-9000 ohms. A reading higher than 9000 ohms indicates a possible open circuit. A reading lower than 7500 ohms indicates a shorted circuit.

Pickup Coil Test

The pickup coil can be checked for an open circuit and shorts with an ohmmeter. If the pickup coil fails either one of the following checks, replace it.

1. Remove the flame arrester cover (4.3 GL and GS Models Only). Remove screws securing distributor cap. Remove cap and rotor.
2. Release locking tab **E** and unplug pickup coil connector.
3. To check for a short to ground, connect ohmmeter to the body of distributor and either terminal **F** or **G**. With the ohmmeter set on the high scale, reading should be infinite (∞). A reading of less than infinity (∞) indicates a shorted circuit.
4. To check for an open or shorted coil, connect ohmmeter to terminals **F** and **G**. With the ohmmeter set on the high scale, a good coil should have a constant value between 700 and 900 ohms. A reading higher than 900 ohms indicates a possible open circuit. A reading lower than 700 ohms indicated a shorted circuit.

Ignition Module Test

The distributor's ignition module has only two failure modes, "No spark" and "No spark advance". After all other checks have been made and these conditions still exist, replace ignition module.

Distributor Removal

See *EFI Diagnostic Workshop Manual 7742218* for Fuel Injected engine distributor removal.

1. Disconnect high tension leads from distributor cap.
2. Lift locking tabs **A** and unplug connector from the distributor. Crank engine so number 1 cylinder is in firing position. Make a mark **B** on distributor base and engine, so the distributor can be replaced in its original position during installation.
3. Remove two attaching screws and distributor cap. Note rotor tip position, and place a reference mark at this point on distributor housing so rotor/distributor housing can be realigned during installation.

NOTE! If engine is cranked while distributor is out, complete ignition timing procedure must be followed. See *Timing Out of Synch* on page 59 and See *Setting Initial Timing* on page 60.

4. Remove distributor clamp and lift distributor from engine. Discard gasket.

NOTE! Use special tool 888863 to remove and install tamper proof screw on 3.0GL-B, 4.3GL-C, 5.0GL-D, 5.7GL-D and later engines.

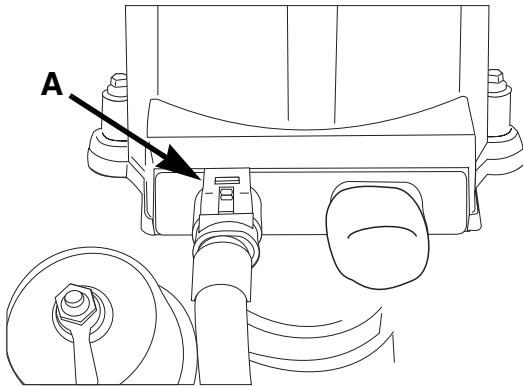

23342

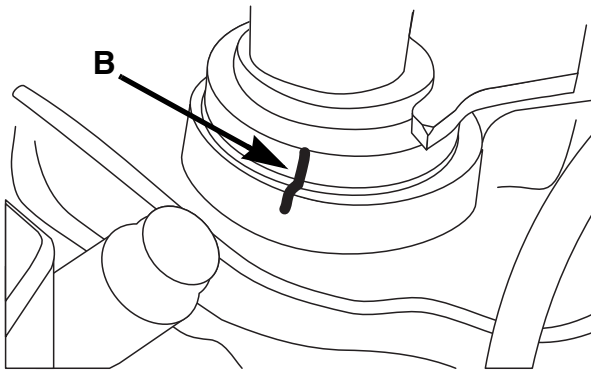

23089

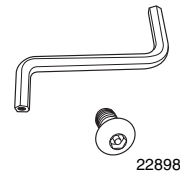

22898

Distributor Service



CAUTION!

Do not substitute automotive parts. Volvo Penta marine components meet U.S. Coast Guard regulations for external ignition proof operation and marine use. Volvo Penta marine components are specially designed not to cause ignition of fuel vapors in the bilge or engine compartment. The use of automotive parts can result in fire and explosion.

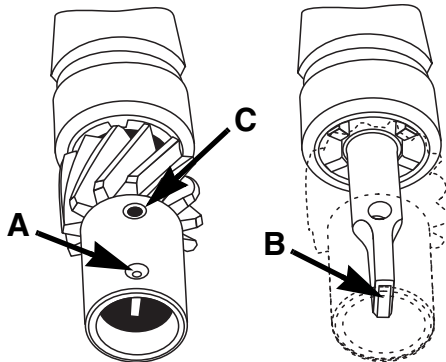

23086

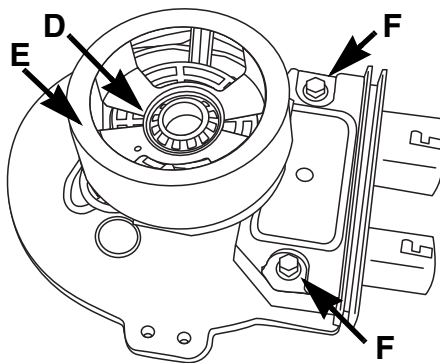

23101

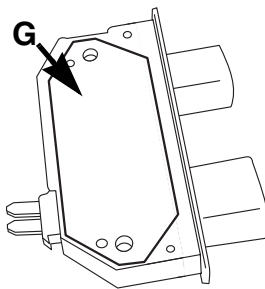

23115

Disassembly

Remove distributor from engine (if necessary) following previous procedure.

Ignition Pickup Coil:

1. Pull off rotor.
2. Place a mark on the gear **A** and the drive tang **B** so that the gear can be re-installed in its original location. Drive pin **C** from gear and remove shaft assembly.
3. Detach leads from module. Pry off retainer **D**, and remove pickup coil **E**.

Ignition Module:

Detach leads and remove the mounting screws **F**. Remove module. Module may be stuck to housing and require prying off.

Reassembly

Ignition Module:

1. Clean old heat sink compound or silicone grease from mounting surfaces **G** of module and distributor.
2. Apply Heat Sink Compound or silicone grease to mounting surface of module.

NOTE! Heat sink compound or silicone grease is necessary for proper heat dissipation.

3. Position module on mounting area of distributor and install the two mounting screws **F**. Tighten securely.

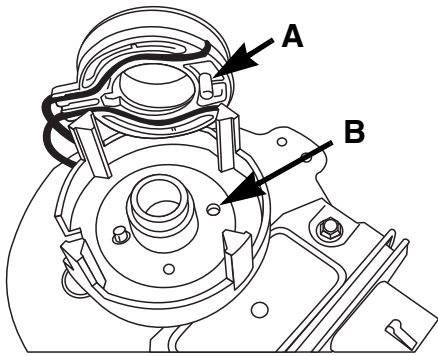

23114

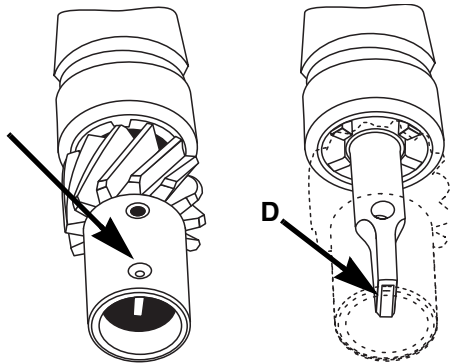

23086

Ignition Pickup Coil:

1. Align tab **A** and hole **B** and attach pickup coil to pole piece as shown. Reattach pickup coil leads to module.
2. Install retainer with locking tabs securely positioned in shaft groove.

Shaft, Gear and Rotor:

1. Install shaft into housing and assemble gear on shaft. Align gear **C** with tang mark **D** and secure with roll pin.
2. Align rotor with notch in shaft and press on securely.

Distributor Installation

See *EFI Diagnostic Workshop Manual 7742218* for Fuel Injected Engines

Engine Not Disturbed

NOTE! Use this procedure if the rotor/housing/block relationship was marked and the crankshaft has not been rotated. If ignition/valve timing relationship has been disrupted or if engine has been cranked with distributor out, install distributor following *Timing Out of Synch* procedure.

1. Position rotor about one-eighth turn counter-clockwise from the rotor reference mark previously placed on the distributor housing.
2. Place a new distributor gasket on engine block. Align reference mark on distributor housing with mark on engine. Push distributor down into block until the housing is in a normal installed position.

NOTE! It may be necessary to move rotor slightly to engage distributor with camshaft gear and oil pump driveshaft, but rotor/housing/block reference marks should properly align when distributor is down in place.

3. Reinstall hold-down clamp and screw. Tighten screw enough so you can just turn the distributor. Attach the connector(s) to the distributor.
4. **Install distributor cap. Tighten screws securely to maintain external ignition proof characteristics.** Lubricate sockets in the distributor cap with **EP/Wheel Bearing Grease** or equivalent and install spark plug wires if they were removed.
5. Time ignition as required. For additional information, see *Setting Initial Timing* on page 60.

Timing Out of Sync

NOTE! Use this procedure if the rotor/housing/block relationship was not marked, or if the crankshaft has been rotated and the ignition timing is completely off.

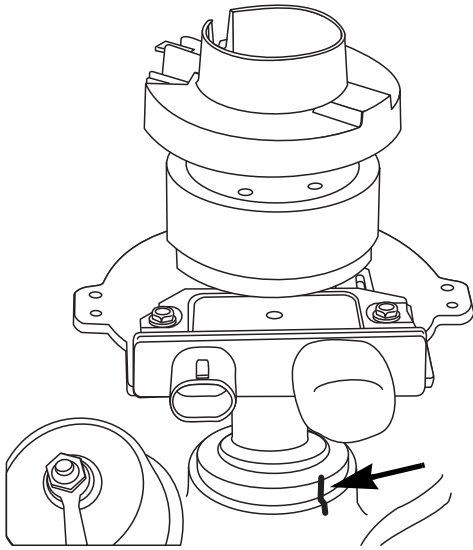

23118

1. Move number 1 piston to firing position (both valves for number 1 cylinder are completely closed) and align harmonic balancer timing mark with timing grid. Number 1 cylinder is now in position to fire.
2. Install distributor into engine. After distributor seats, rotor must be in position to fire number 1 cylinder as shown.

If distributor does not seat in engine block, press down lightly on distributor housing while turning rotor. After distributor engages oil pump shaft, install distributor clamp and bolt, leaving bolt just loose enough to permit movement of distributor with heavy hand pressure.

3. Place cap on distributor housing. Rotate housing left or right until rotor lines up with terminal for number 1 spark plug wire.
4. Check all high tension wiring, and connect spark plugs wires to cap in proper sequence if they have been removed.
5. Attach connector(s) to distributor. Continue on to **Setting Initial Timing** procedure.



WARNING! To prevent a possible explosion, operate the blower as recommended by the boat manufacturer before starting engine. If the boat is not equipped with bilge blower, open engine cover or hatch prior to starting and leave open until after engine is running.

Setting Initial Timing

The timing mark is stamped on the rim of the harmonic balancer. The timing grid is a scale attached to the timing chain cover. The timing grid displays Top Dead Center (marked "0") and degrees of advance (before) or retard (after). Each division on the scale represents 2 degrees.

Preparation

1. Connect a 12-volt timing light to number 1 spark plug lead, and use the timing light following the manufacturer's instructions.

Be careful not to puncture the wire or boot as this would cause a high voltage leak. Make sure that spark plug wires are pushed all the way down into the distributor cap terminals and onto the spark plugs. Nipples must be firmly pushed over the terminals, and boots over the spark plugs. **Failure to do so can result in ignition of fuel vapors in engine compartment or bilge, and may result in fire or explosion.**

2. Start engine and leave running until thoroughly warmed up.



WARNING! Have someone at controls. Keep hands, hair and clothing away from rotating parts while making adjustments when engine is running.

3. Adjust idle speed to specified in-gear RPM, then shift into NEUTRAL. Shut off engine.

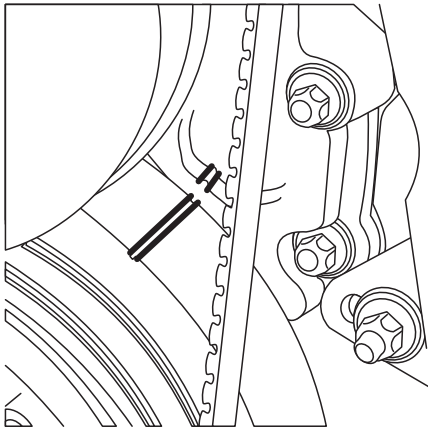

23116

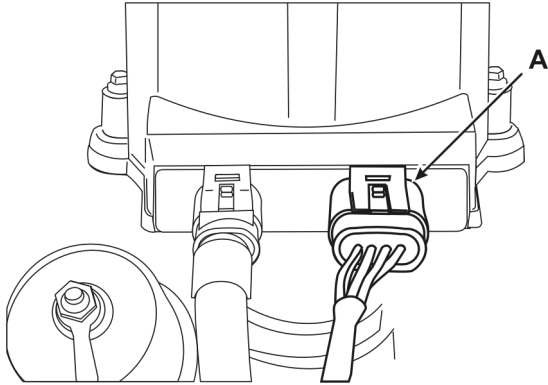

23109-a

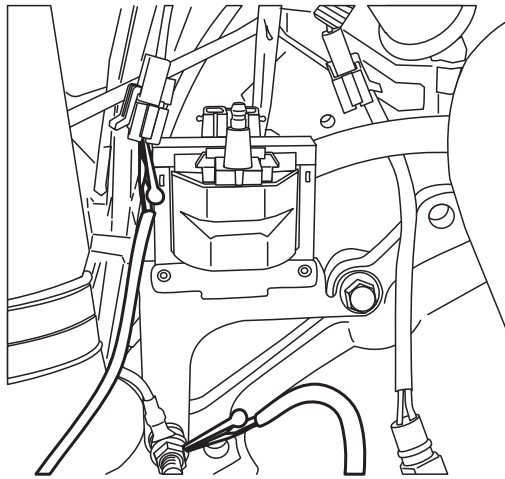

23103

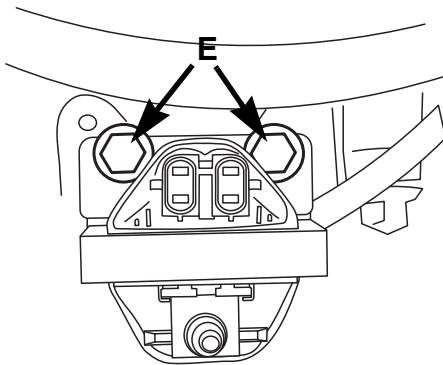

23087

Setting Timing

The timing procedure for Delco EST system requires shunting (shutting off) the electronic spark advance. Follow the steps that apply to your specific model.

1. Install Timing Test Lead, Volvo Penta P/N 885163-6 **A**, into distributor and connect bare lead to a 12-volt engine B+ source. Start engine.
2. Direct beam of timing light onto timing grid. Loosen distributor clamp, then turn distributor slowly by hand until timing mark is set at the appropriate timing figure. **See Ignition Timing Advance** on page 64. Recheck timing mark; reset if necessary. Tighten clamp bolt.
3. Stop engine. Remove adaptor plug.

Ignition Coil Replacement

1. Remove ignition coil to distributor cap high tension lead, two pin connector (purple and gray wires), and two pin connector (pink and brown wires) from the ignition coil.
2. Remove two screws **E** securing coil to engine block and remove ignition coil.
3. Place coil in a vise. Wear eye protection. Remove two rivet heads . Drive the rivets out of the coil. Save the bracket pieces .
4. Assemble the two bracket pieces and the coil using two screws and nuts provided in the replacement ignition coil kit. Tighten screws securely.
5. Mount the coil assembly to the engine block. Secure with two bolts **E**. Tighten to 20-25 ft. lb. (27-34 Nm).

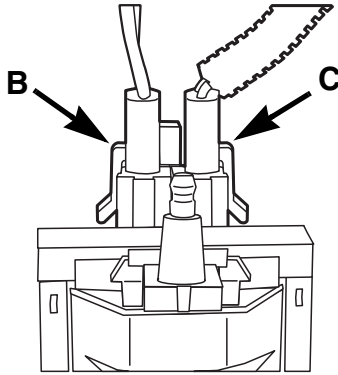

23119

6. Attach two pin connector (pink and brown wires) **C** to the coil as shown. Attach two pin connector (purple and gray wires) **B** to the coil as shown.
7. Apply **EP/Wheel Bearing Grease** or equivalent to the high tension lead terminal **F** and attach it to the ignition coil.

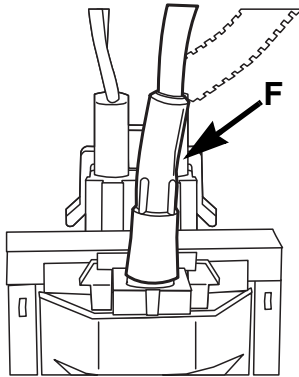

23135

Ignition System Problems

Engine runs sluggish, overheats

Check:

- Timing
- For proper fuel
- Compression and for carbon buildup

Engine pings

Check:

- Timing
- For proper fuel
- Compression and for carbon buildup
- Spark plugs for proper heat range

Engine starts hard

Check:

- For spark
- Spark plugs
- Compression
- Battery
- Distributor cap

Engine misfires

Check:

- Spark plugs and leads
- Rotor and distributor cap
- Coil
- Engine firing order and plug wire routing
- Engine timing
- Engine operating in S.L.O.W.

Engine cranks but doesn't start

Check:

- For spark
- Coil primary and secondary circuit wiring
- Tachometer and wiring
- Primary circuit wiring to ignition coil
- Primary circuit wiring to distributor
- Ignition pickup coil
- Ignition module

Specifications

Ignition Timing Advance

3.0 All Models¹

Engine RPM	86 AKI Fuel
Initial	-2°
600 RPM	8°
1000 RPM	13°
1500 RPM	15°
2000 RPM	17°
2500 RPM	18°
3000 RPM	19°
3500 RPM	20°
4000 RPM	20°
4600 RPM	21°

4.3GL Models¹

Engine RPM	86 AKI Fuel
Initial	1°
600	18°
1000	21°
1500	23°
2000	24°
2500	25°
3000	25°
3500	25°
4000	25°
4600	25°

5.0GL-B/C/D/E Models¹

Engine RPM	89 AKI Fuel
Initial	10°
600	19°
800	22°
1200	25°
1600	26°
2000	27°
2400	28°
2800	28°
4000	28°
4800	28°

5.7GL-B/C/D/E Models¹

Engine RPM	89 AKI Fuel
Initial	12°
600	21°
800	24°
1200	27°
1600	28°
2000	29°
2400	30°
2800	30°
4000	30°
4800	30°

Ignition Components

Ignition Coil -HEI

Primary Resistance, in Ohms @ 75° F . 0.35-0.45
 Secondary Resistance, in Ohms @ 75° F . . 7500-9000

Pickup Coil

Resistance, in Ohms @ 75° F 700-900

1. 3.0GL-B/C, 4.3GL-C/D, 5.0GL-D/E, 5.7GL-D/E and later models require special tool P/N 888863 to adjust ignition timing

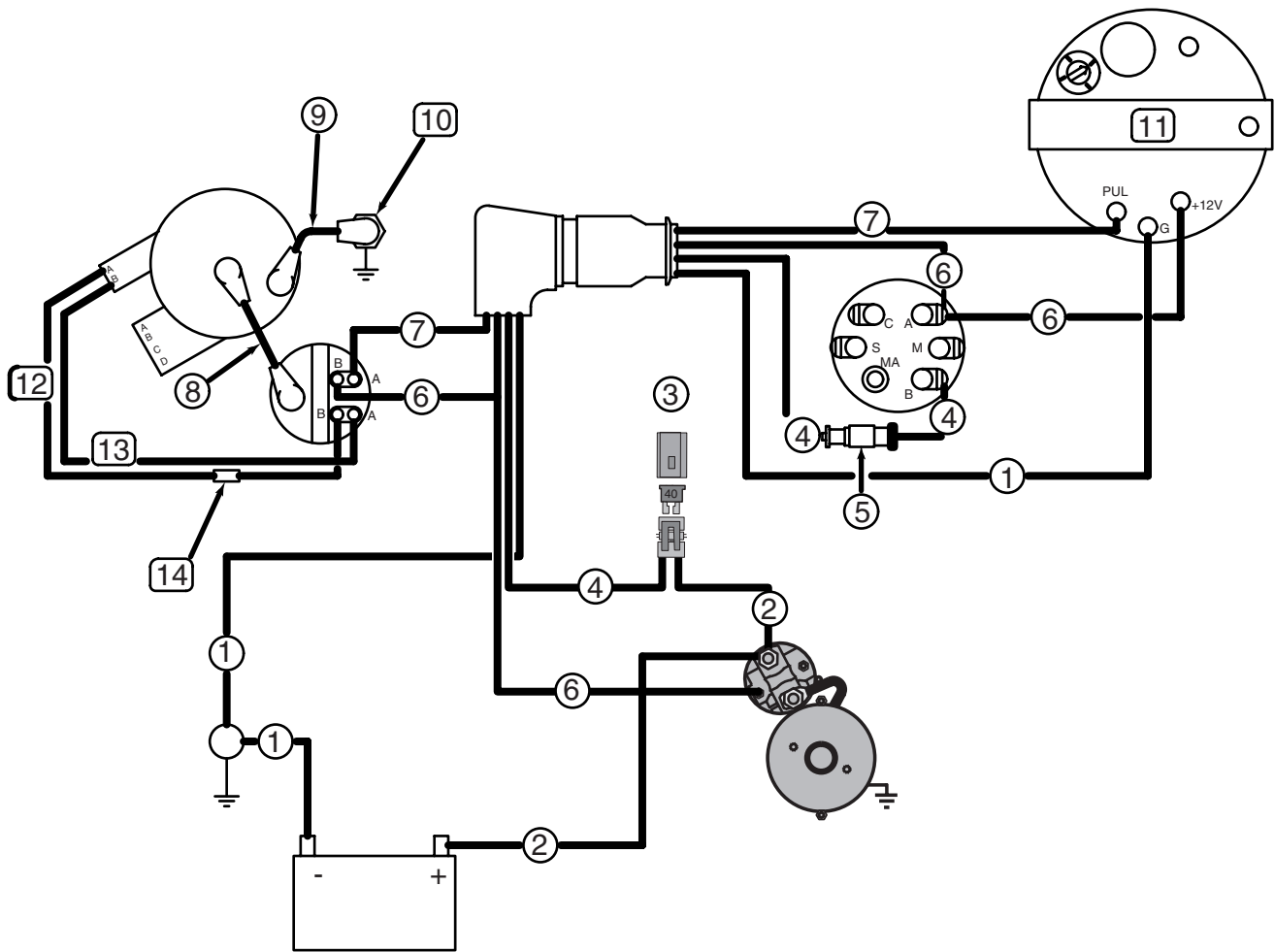

DRC7516

Ignition Circuit

Models: 3.0 GS-A/B/C, 3.0GL-A/B, 4.3 GLA/B/C, 5.0GL-B/C/D, 5.7GL-B/C/D

1. Black
2. Red
3. 40 Amp Fuse
4. Red/Purple
5. 20 Amp Fuse
6. Purple
7. Gray
8. High Tension Lead
9. Spark Plug Lead
10. Spark Plug
11. Tachometer
12. Pink
13. Brown
14. Inductor

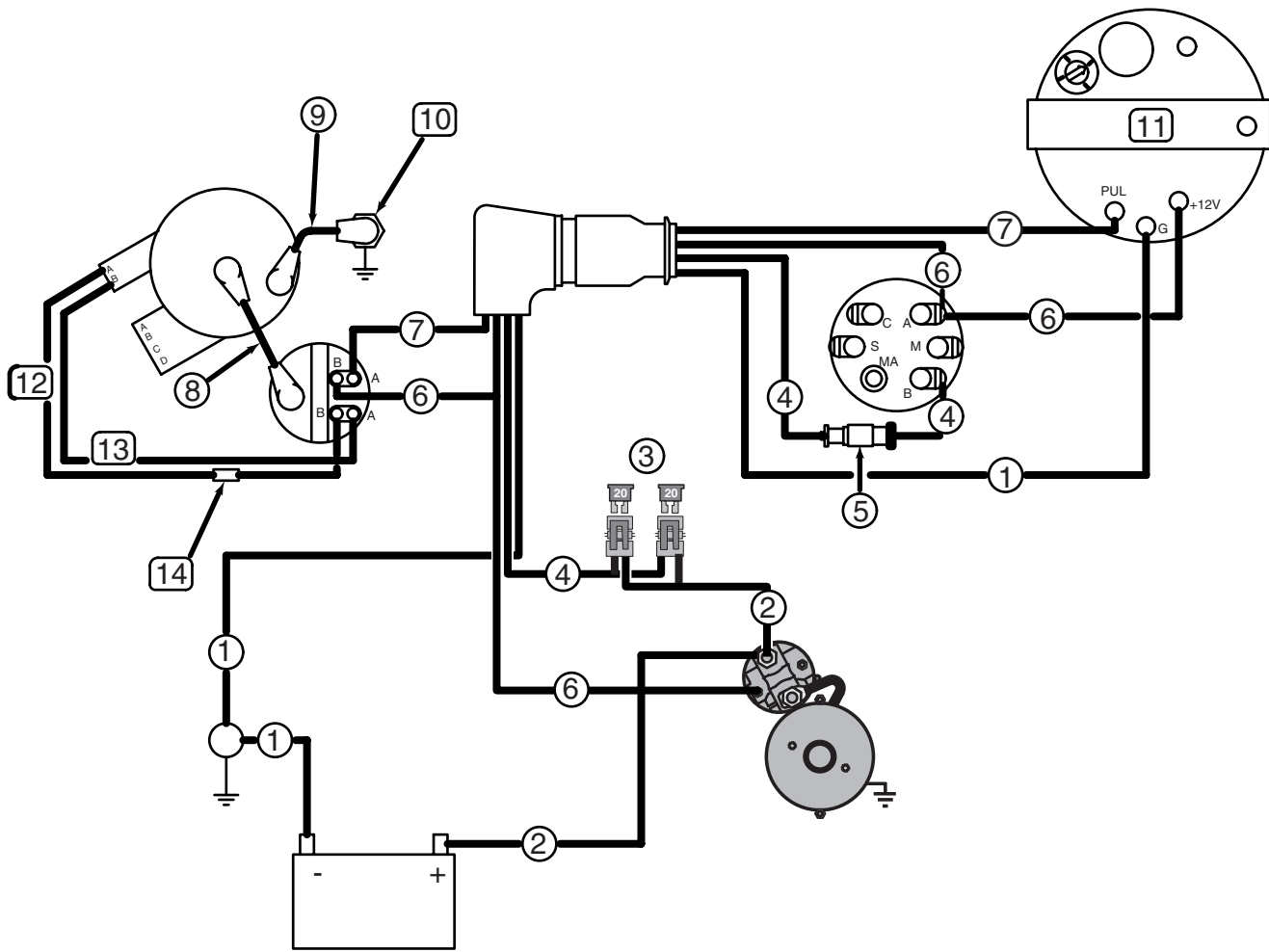

23106

Models: 3.0 GL-C, 4.3GL-D, 5.0GL-E, 5.7GL-E

- | | |
|--------------------|----------------------|
| 1. Black | 8. High Tension Lead |
| 2. Red | 9. Spark Plug Lead |
| 3. 20 Amp Fuse X 2 | 10. Spark Plug |
| 4. Red/Purple | 11. Tachometer |
| 5. 20 Amp Fuse | 12. Pink |
| 6. Purple | 13. Brown |
| 7. Gray | 14. Inductor |