

**UNDERHOOD ACCESSORY WIRING JU...**

**UNDERHOOD ACCESSORY WIRING JUNCTION BLOCK LABEL (WIRING SYSTEMS)**

Document ID# 474212

**Underhood Accessory Wiring Junction Block Label**

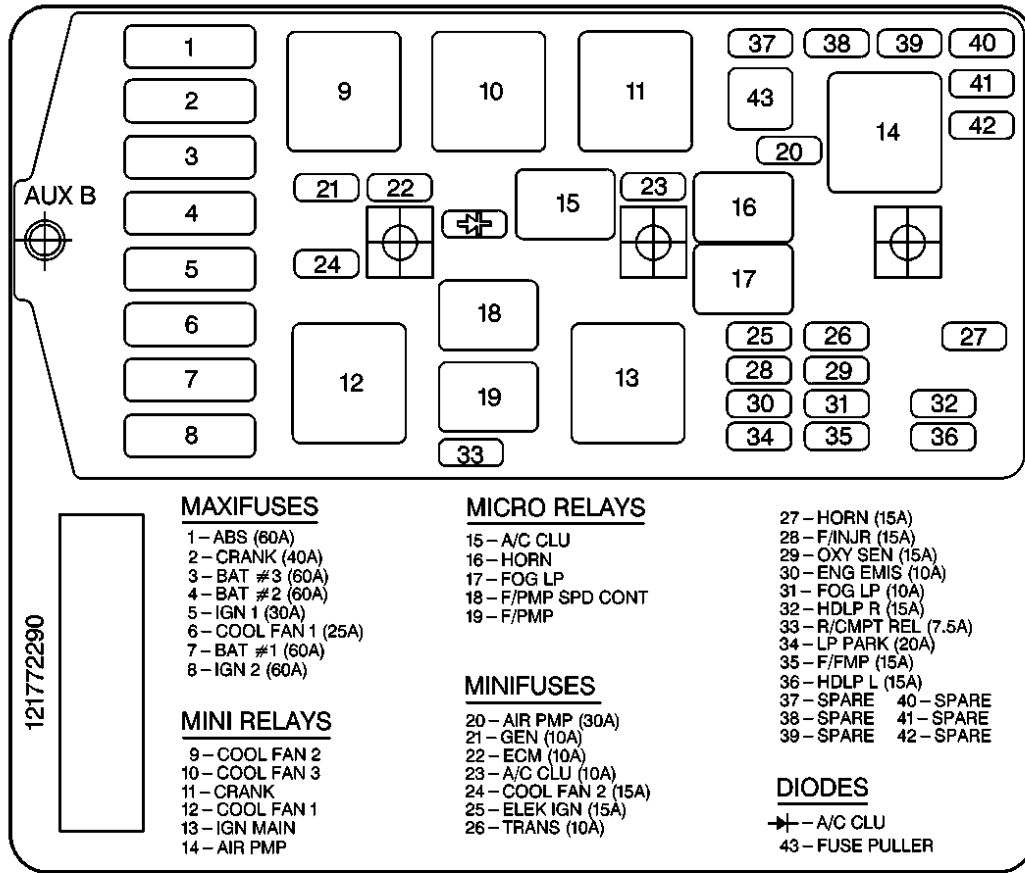

**Underhood Accessory Wiring Junction Block (RPO L82)**

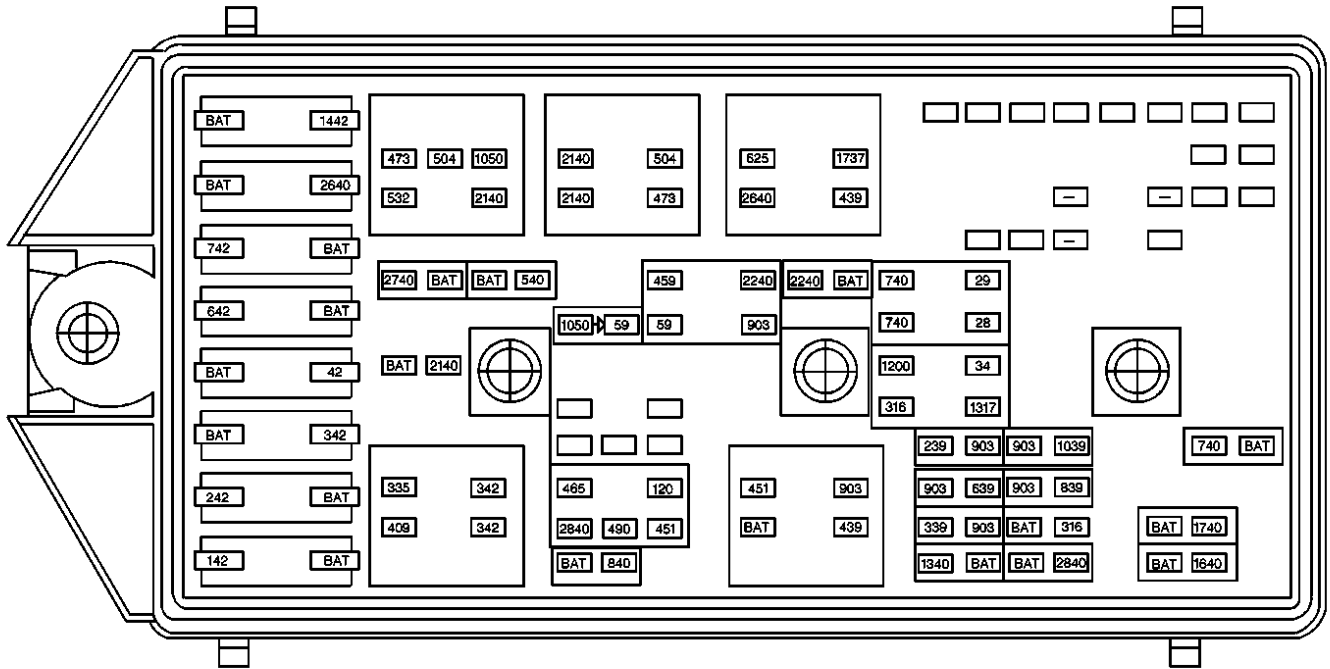

**Underhood Accessory Wiring Junction Block (RPO L36, and L67)**

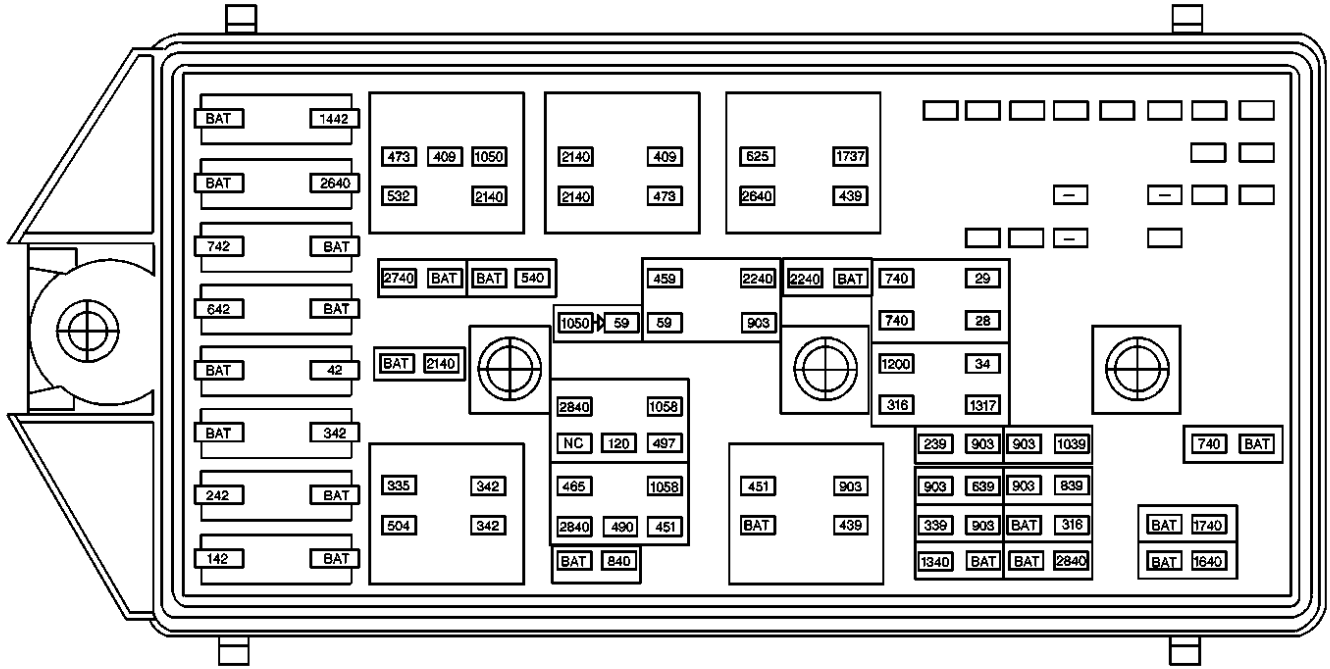

**I/P Fuse Block**

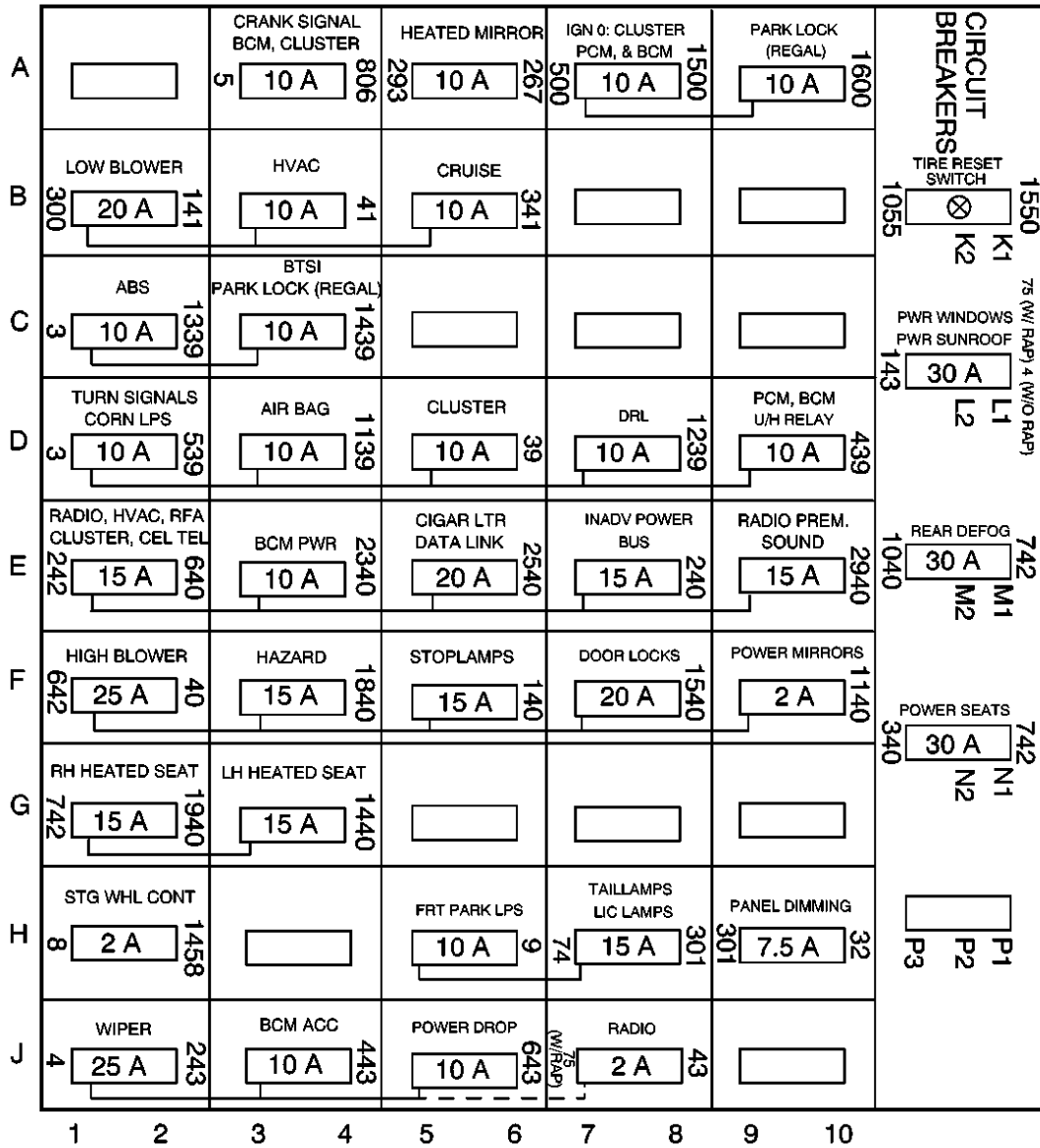

**Cell 11: R/CMPT REL, ECM, GEN, F/PMP, FOG LP, A/C CLU, and HORN Fuses**

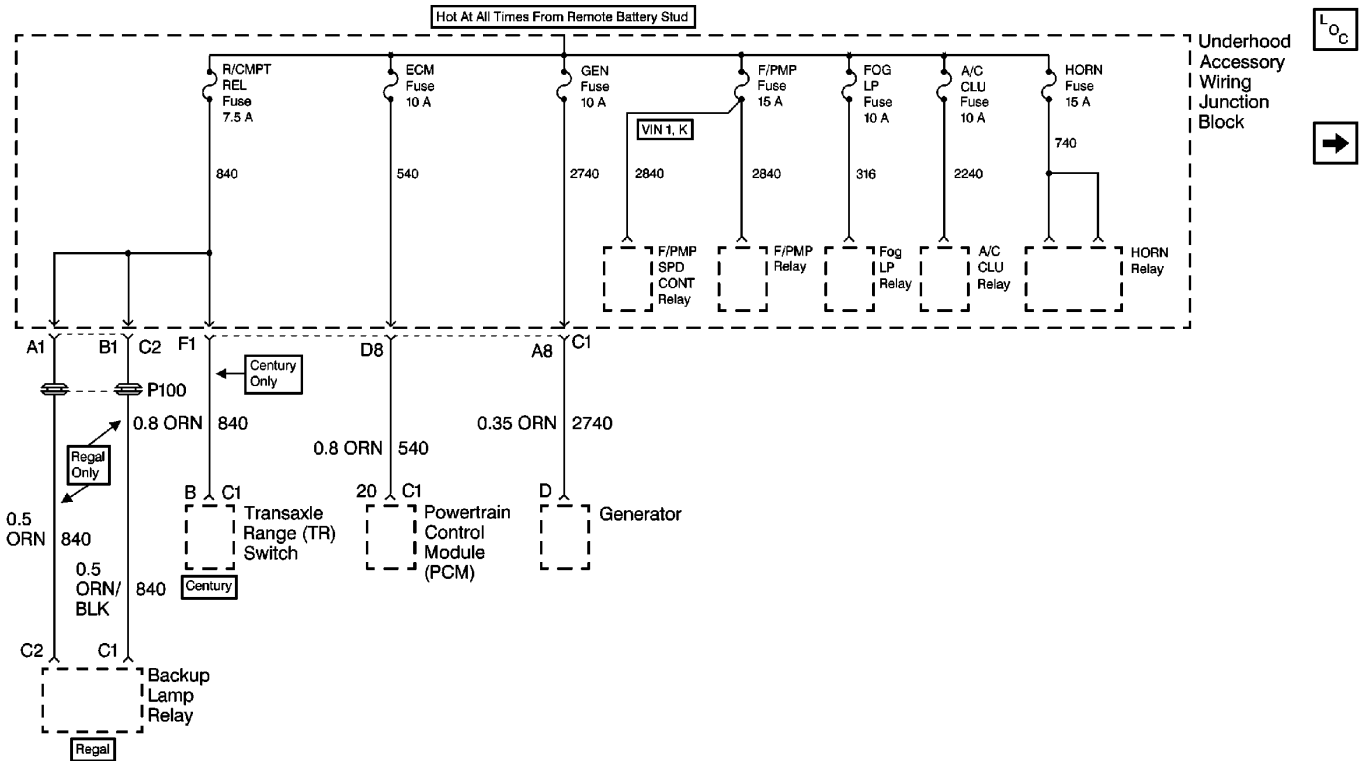

**Cell 11: LP PARK, HDLP L and HDLP R Fuses**

LOC

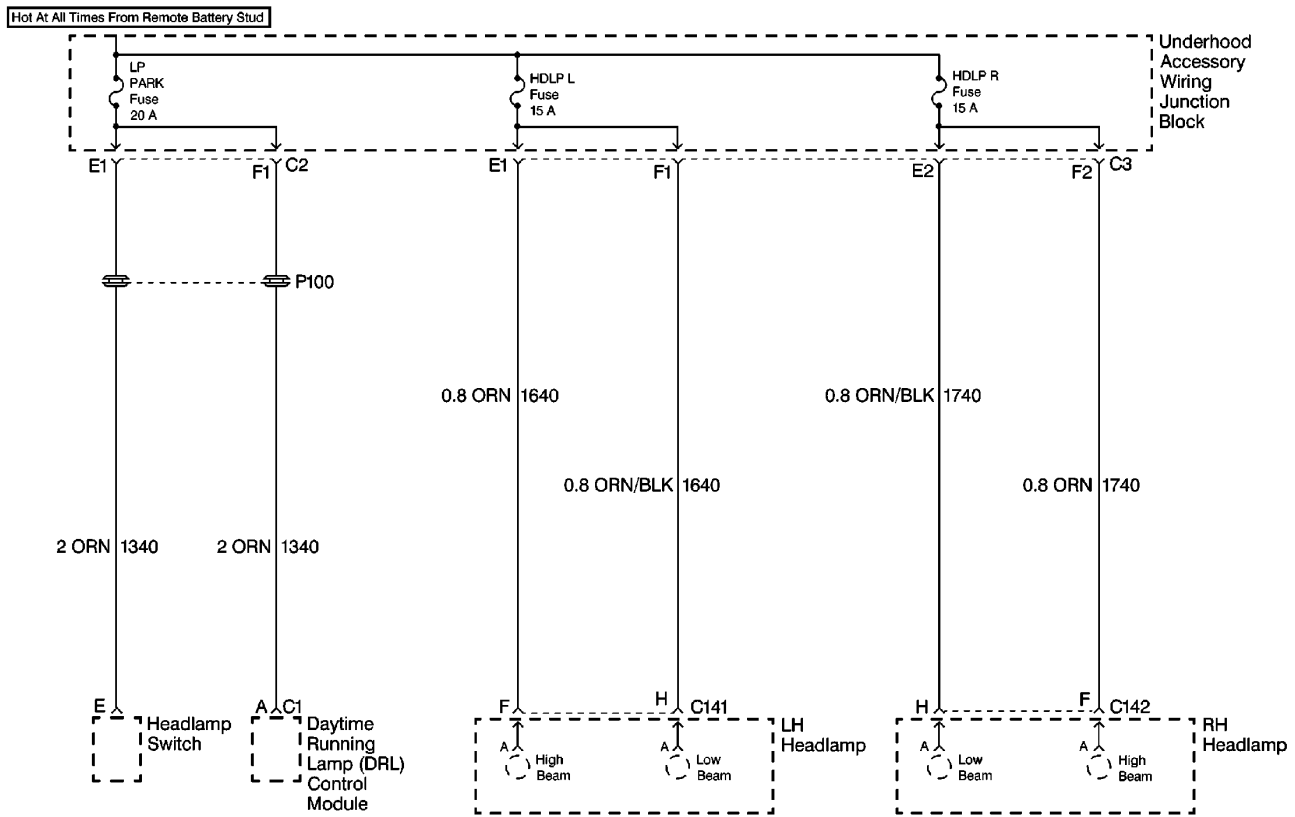

**Cell 11: ENG EMIS Fuse**

LOC

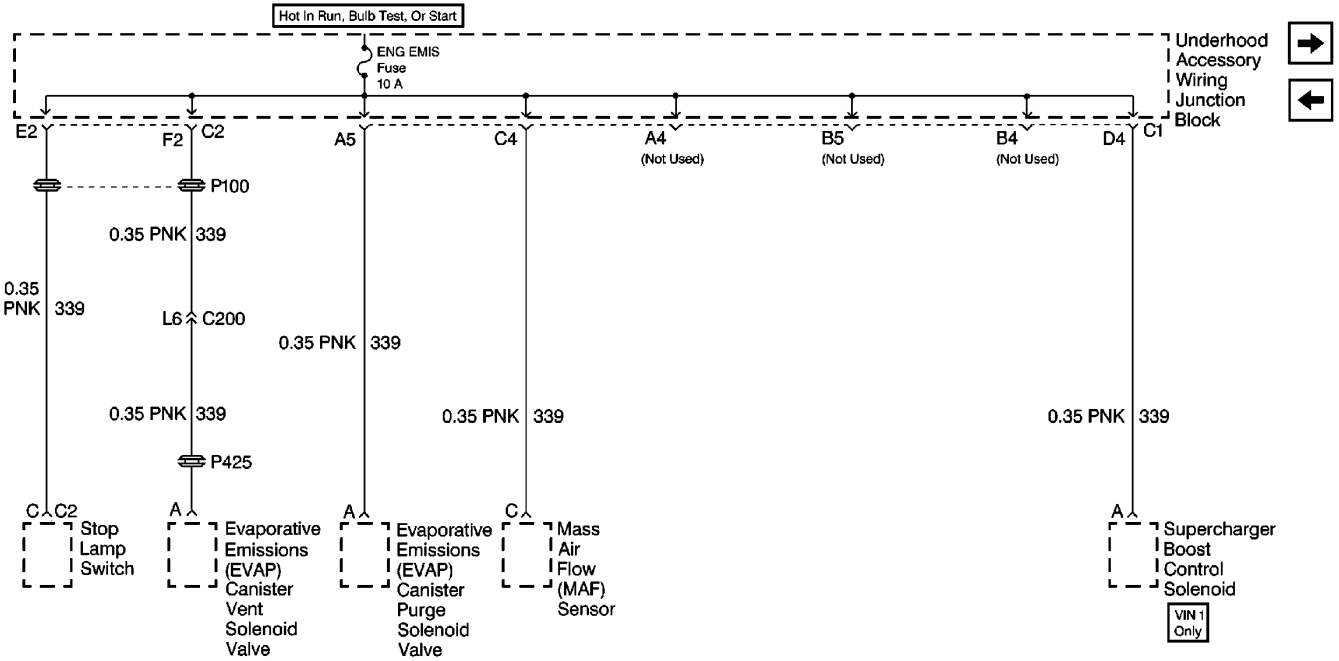

**Cell 11: TRANS, ELEK IGN and OXY SEN Fuses**

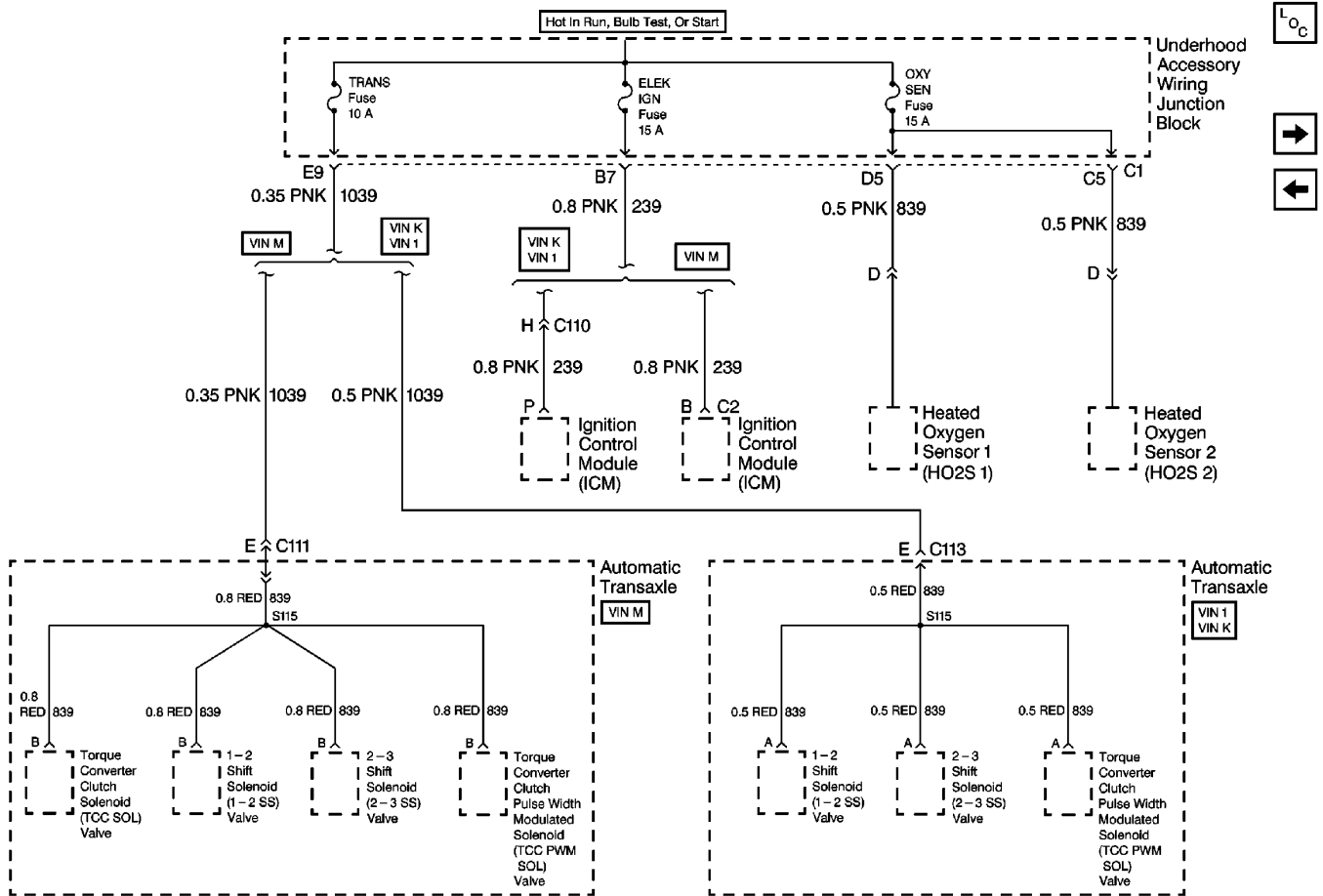

**Cell 11: F/INJR Fuse**



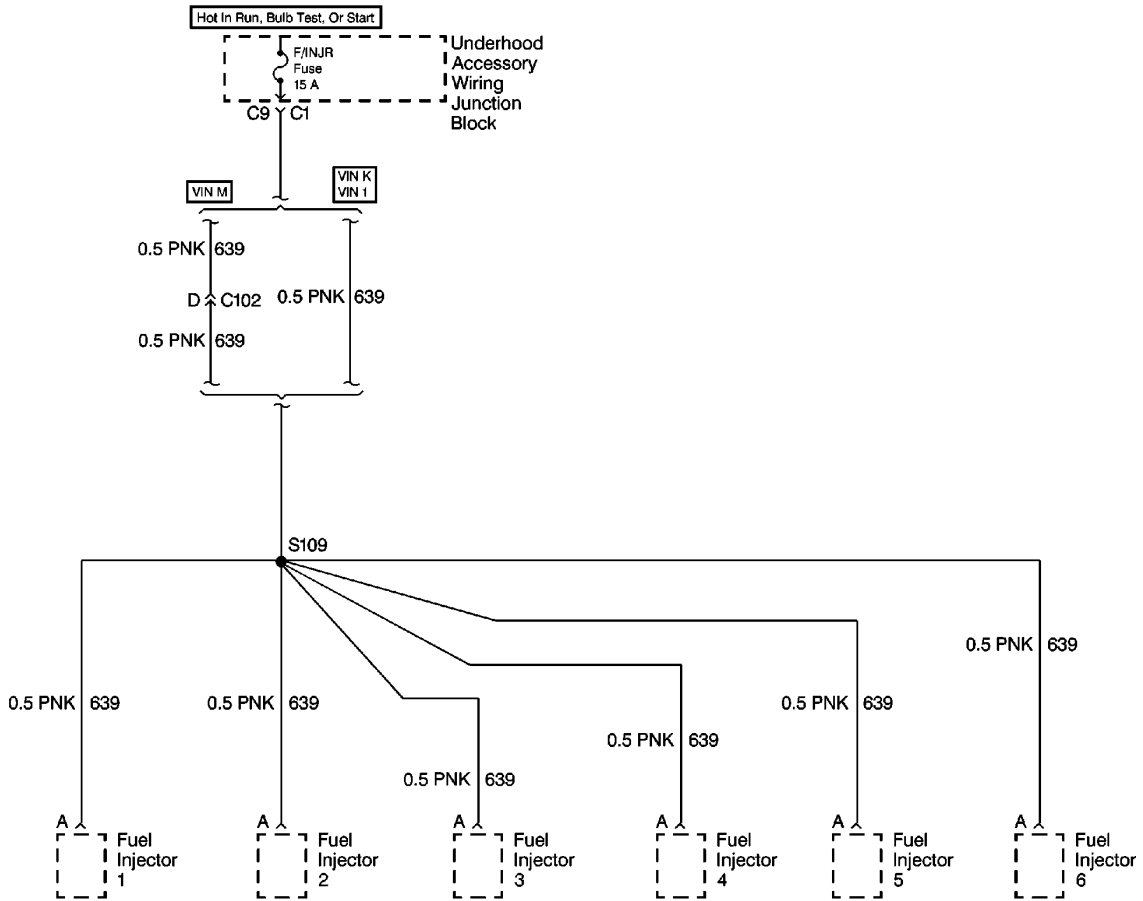

**Cell 11: HEATED MIRROR, CRANK SIGNAL BCM CLUSTER, IGN 0: CLUSTER PCM & BCM, and PARK LOCK Fuses**

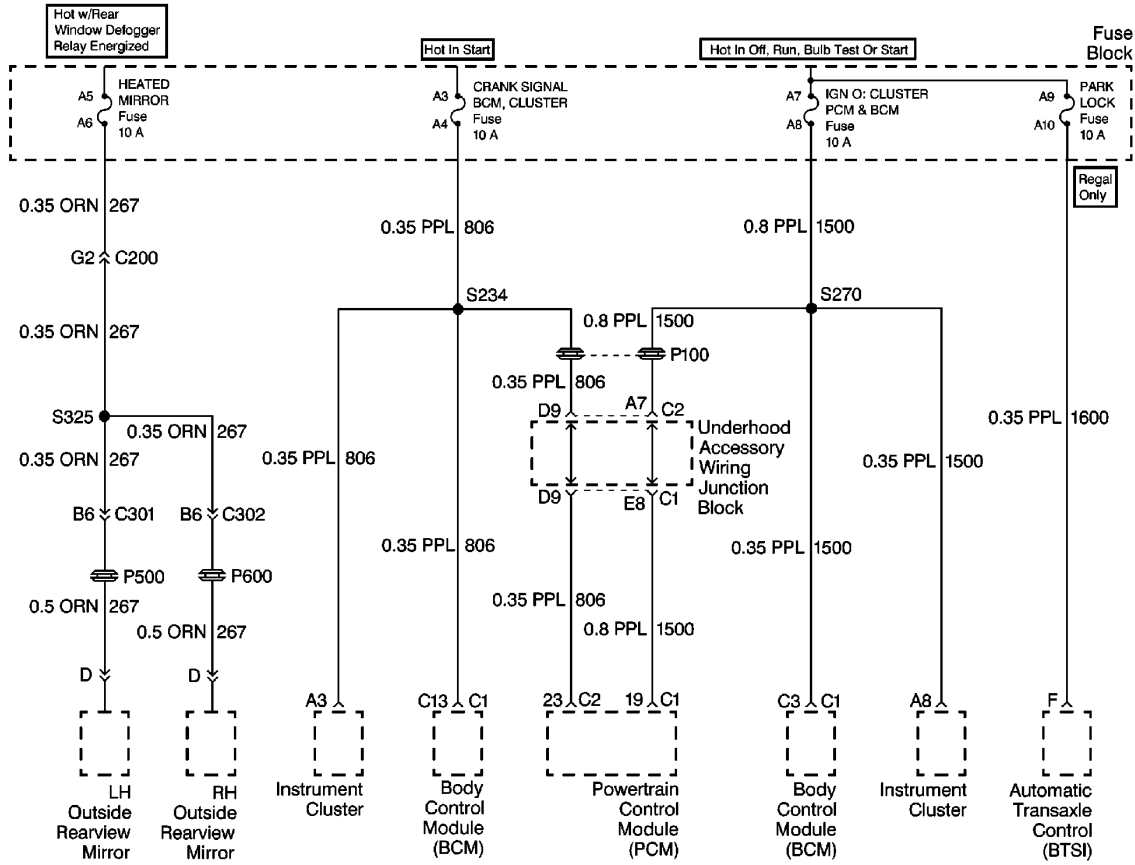

**Cell 11: LOW BLOWER, CRUISE and HVAC Fuses**

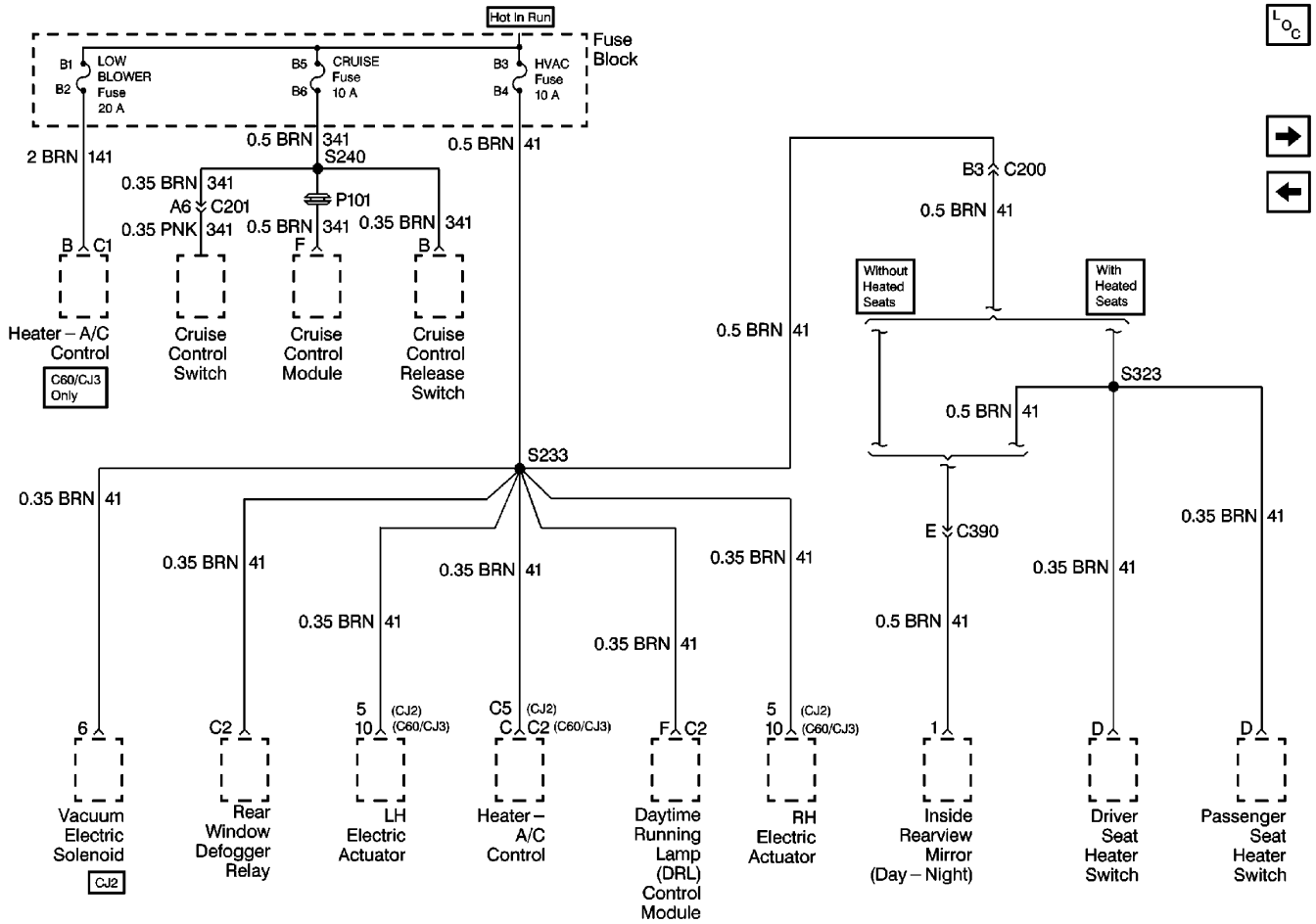

**Cell 11: ABS, and BTSI PARK LOCK Fuses**

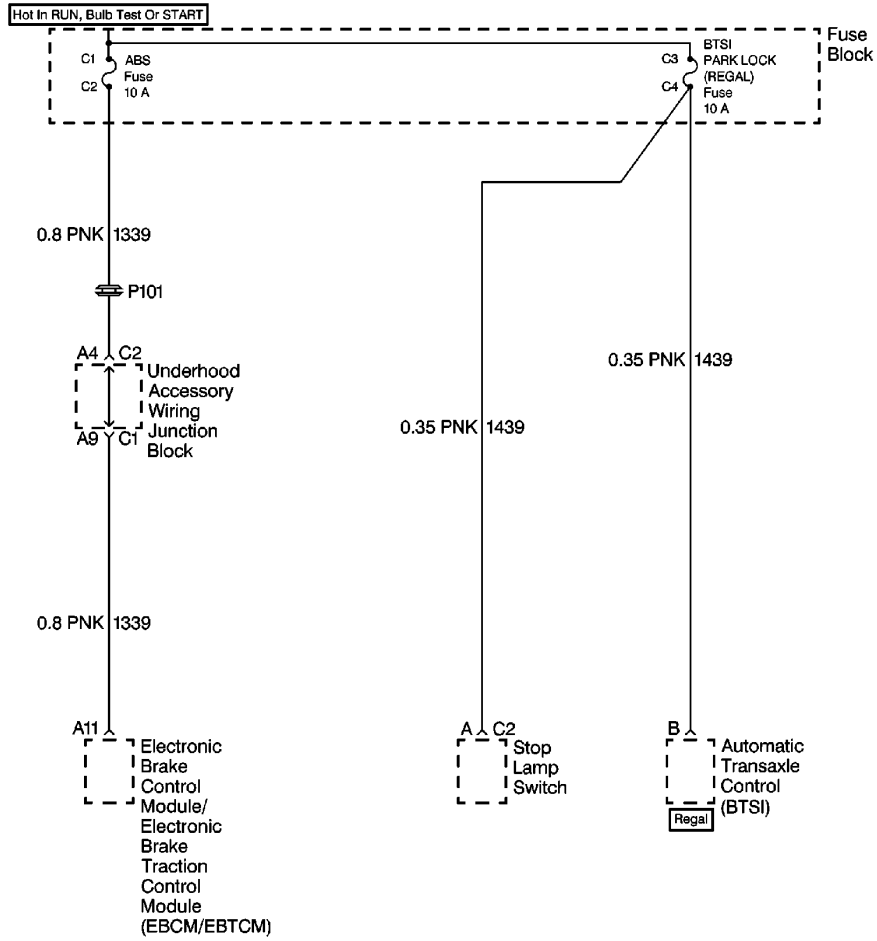

LOC



**Cell 11: TURN SIGNALS CORN LPS, AIR BAG, CLUSTER, DRL and PCM-BCM U/H RELAY Fuses**

LOC

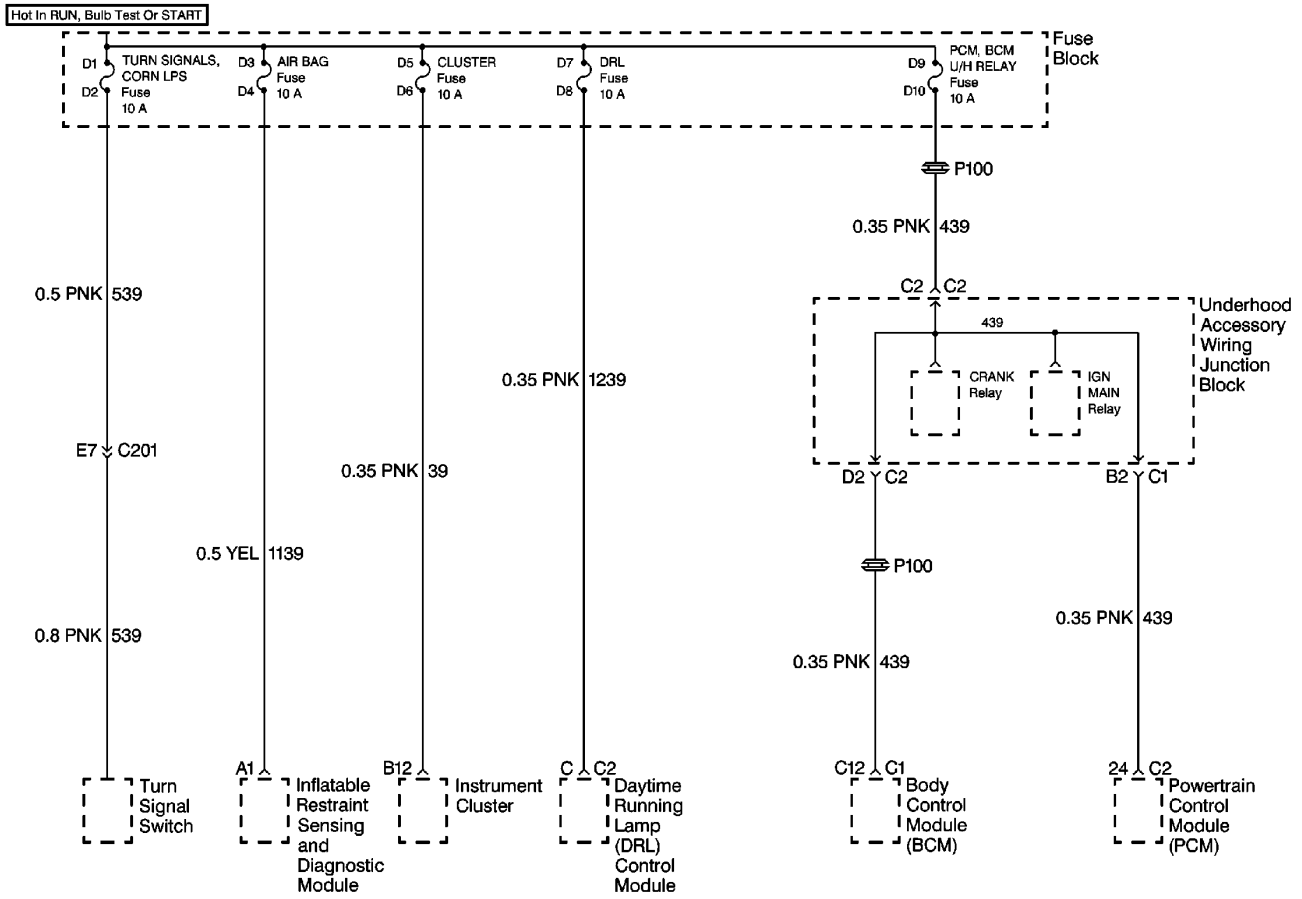

**Cell 11: RADIO-HVAC RFA CLUSTER CEL TEL, BCM PWR, INADV POWER BUS, and CIGAR LTR DATA LINK Fuses**

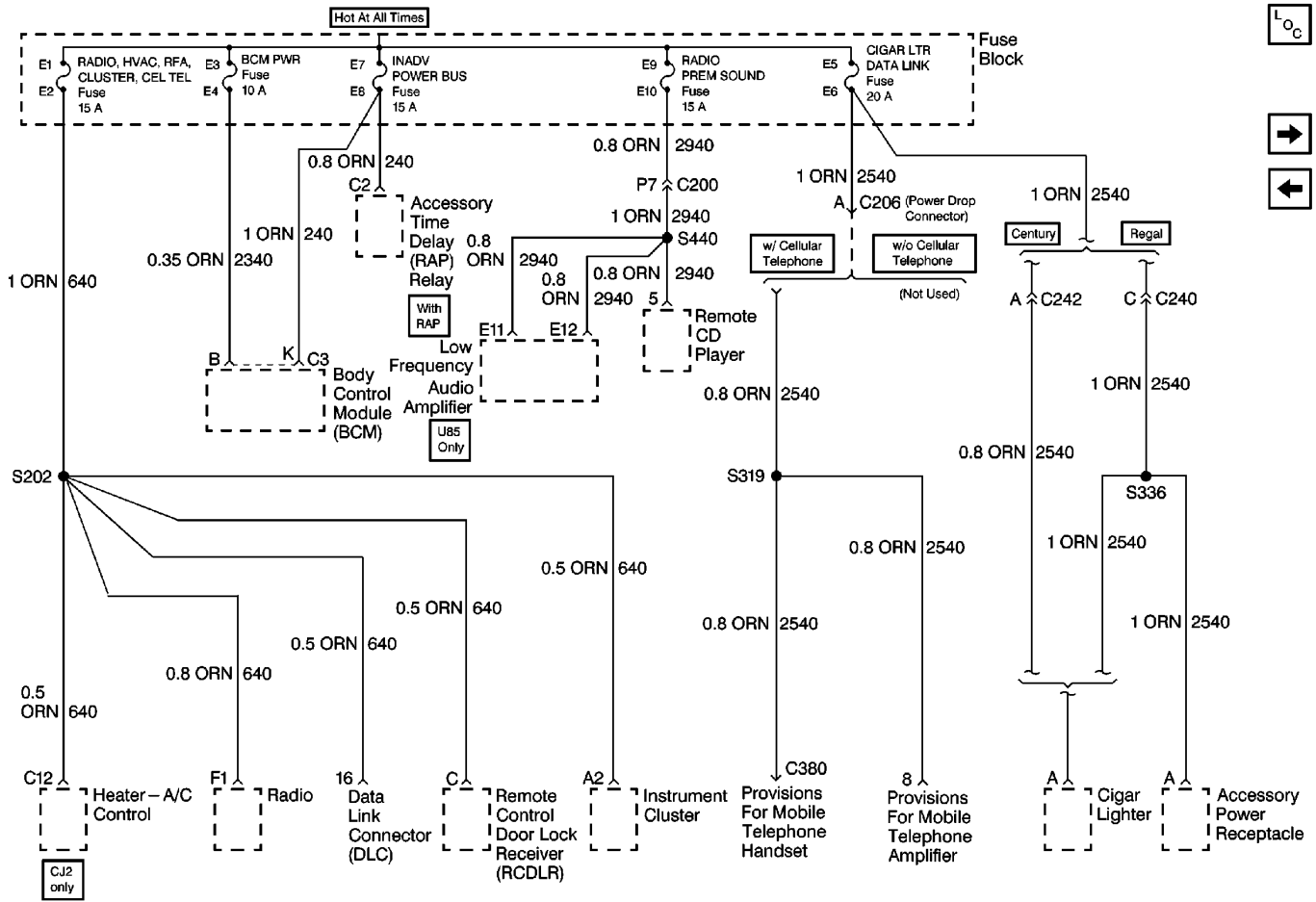

**Cell 11: HIGH BLOWER, HAZARD, STOP LAMPS, DOOR LOCKS, POWER MIRRORS, RH HEATED SEAT AND LH HEATED SEAT Fuses**

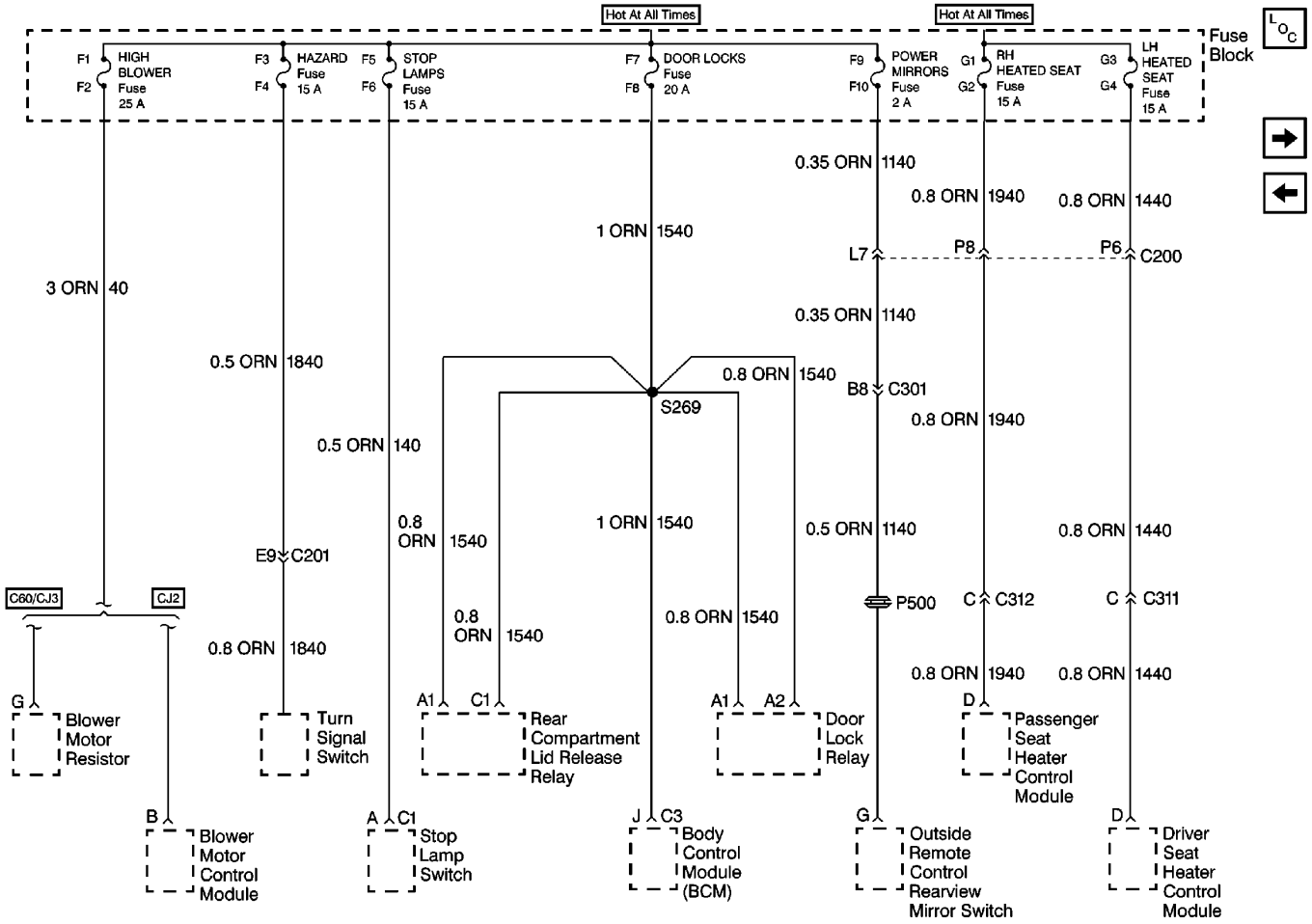

**Cell 11: FRT PARK LPS FOG LAMPS, TAIL LAMPS LIC LAMPS, and PANEL DIMMING Fuses**

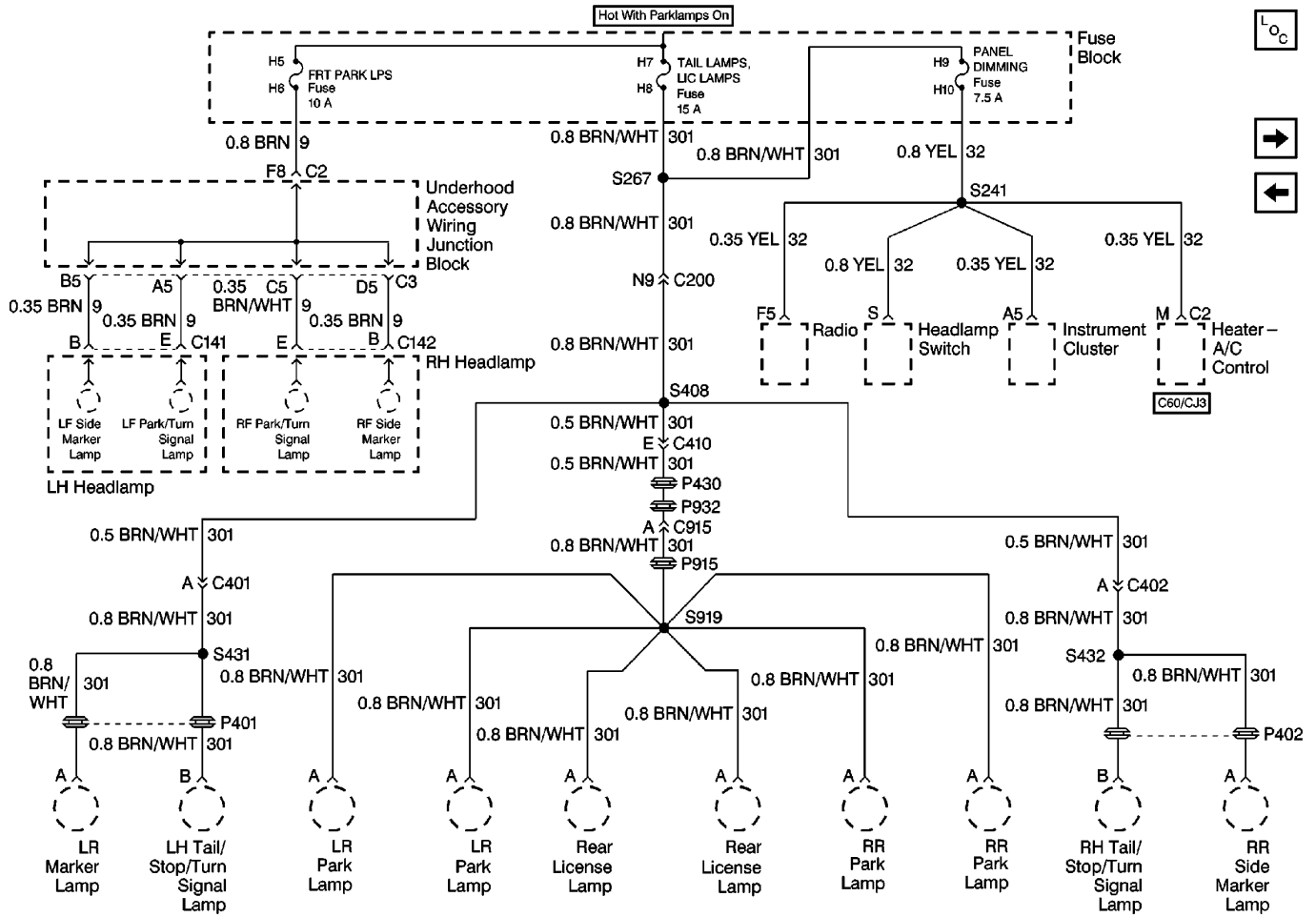

**Cell 11: WIPER, BCM ACC, POWER DROP, RADIO and STRG WHL CONT Fuses**



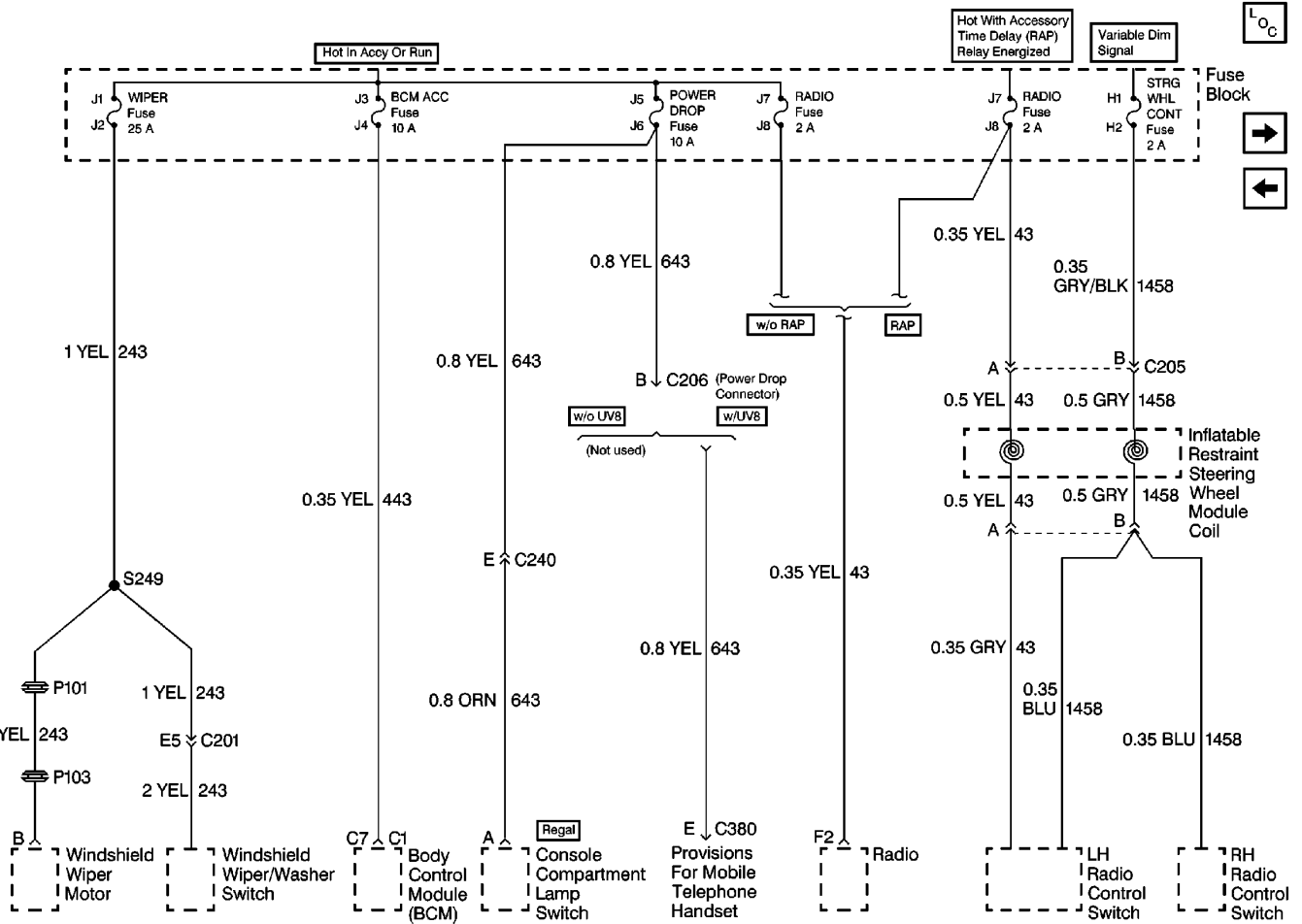

**Cell 11: PWR WINDOWS-PWR SUNROOF, REAR DEFOG and POWER SEATS Circuit Breakers**

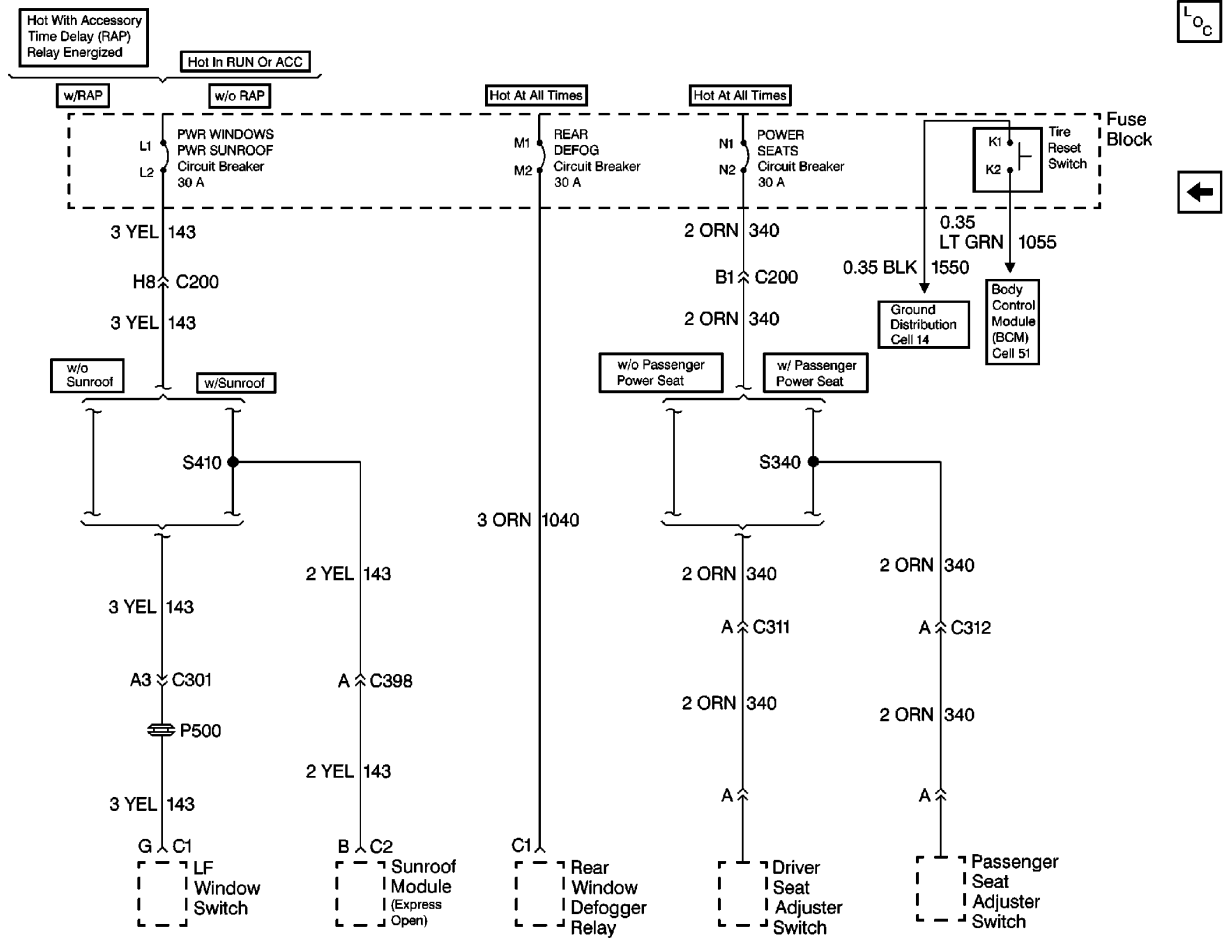

"Portions of materials contained herein have been reprinted with permission of General Motors Corporation, Service and Parts Operations" License Agreement #0410810.

Copyright 2007 - 2012 Service Repair Solutions, Inc.