

X326 BODY HARNESS TO BODY CONTROL MODULE HARNESS

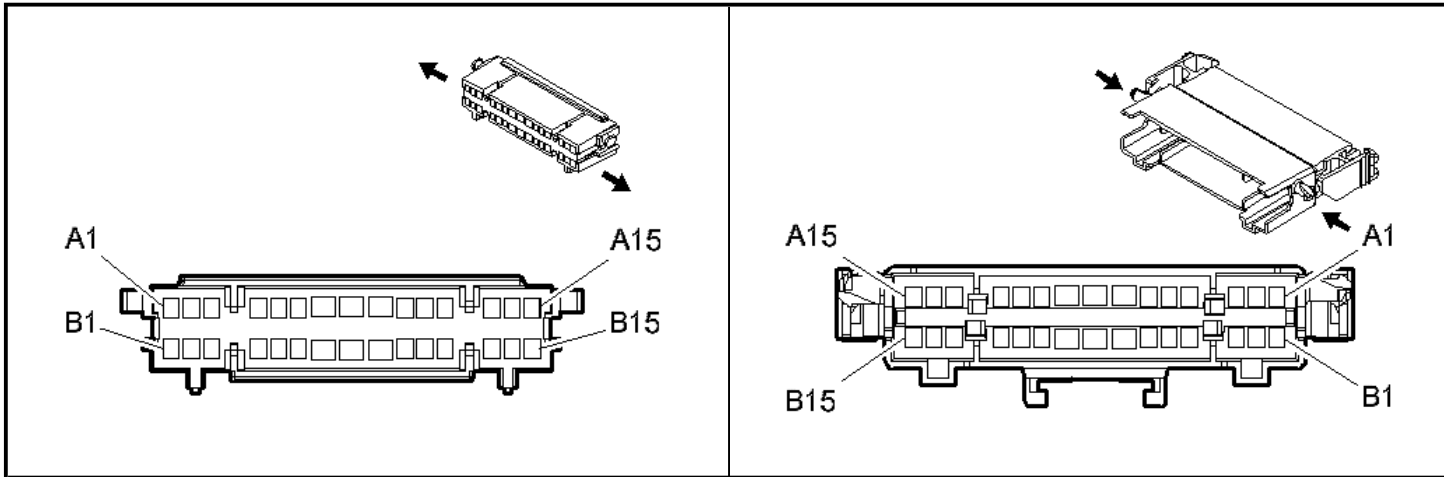

Connector Part Information

- OEM: 15304908
- Service: 15304908
- Description: 30-Way F GT 150/280 Series (BK)

Terminal Part Information

- Pins: A2, A3, A12
- Terminal/Tray: 12191812/19
- Core/Insulation Crimp: C/A
- Pins: A1, A5, A6, B1-B5, B10-B12, A10, A11, A13-A15, B13
- Core/Insulation Crimp: E/C
- Release Tool/Test Probe: 15315247/J-35616-2A (GY)
- Pins: A9
- Terminal/Tray: 15304711/8
- Core/Insulation Crimp: 2/A
- Pins: A7, A8, B7, B9

Connector Part Information

- OEM: 15326762
- Service: 15326762
- Description: 30-Way M GT 150/280 Series (BK)

Terminal Part Information

- Pins: A2, A3, A5, A10, A12, A13, A15
- Terminal/Tray: 15304702/19
- Core/Insulation Crimp: 2/4
- Pins: A6, A11
- Core/Insulation Crimp: E/4
- Pins: A1, B1-B4, B5, B10, B11, A14, B13
- Core/Insulation Crimp: E/C
- Release Tool/Test Probe: 15315247/J-35616-3 (GY)
- Pins: B9
- Terminal/Tray: 15304722/8
- Core/Insulation Crimp: E/C
- Release Tool/Test Probe: 15315247/J-35616-5 (PU)
- Pins: A7, A8, B7, A9
- Terminal/Tray: 15304724/8
- Core/Insulation Crimp: 2/A

2008 Buick Lucerne CX

2008 ELECTRICAL Wiring Systems & Power Management - Lucerne

- Core/Insulation Crimp: E/A
- Release Tool/Test Probe: 15315247/J-35616-4A (PU)
- Release Tool/Test Probe: 15315247/J-35616-5 (PU)
- Pins: B12
- Terminal/Tray: See Terminal Repair Kit
- Core/Insulation Crimp: See Terminal Repair Kit
- Release Tool/Test Probe: See Terminal Repair Kit

X326 Body Harness to Body Control Module Harness

Pin	Wire	Circuit	Function	Pin	Wire	Circuit	Function
A1	0.35 D-BU	6561	Right Cornering Lamp Relay Control (TUH)	A1	0.35 D-BU	6561	Right Cornering Lamp Relay Control (TUH)
A2	0.8 RD/YE	340	Battery Positive Voltage	A2	0.8 RD/YE	340	Battery Positive Voltage
A3	0.8 RD/GN	440	Battery Positive Voltage	A3	0.8 RD/GN	440	Battery Positive Voltage
A4	-	-	Not Used	A4	-	-	Not Used
A5	0.5 YE	18	Left Rear Stop/Turn Lamp Supply Voltage	A5	0.8 YE	18	Left Rear Stop/Turn Lamp Supply Voltage
A6	0.35 PU	169	Power Window Master Switch Left Rear Down Signal	A6	0.35 PU	169	Power Window Master Switch Left Rear Down Signal
A7	0.5 D-GN	19	Right Rear Stop/Turn Lamp Supply Voltage	A7	0.8 D-GN	19	Right Rear Stop/Turn Lamp Supply Voltage
A8	0.35 D-BU/WH	1315	Right Front Turn Signal Lamp Supply Voltage	A8	0.35 D-BU/WH	1315	Right Front Turn Signal Lamp Supply Voltage
	0.35 D-BU/WH	1315	Right Front Turn Signal Lamp Supply Voltage				
A9	0.8 RD/WH	1240	Battery Positive Voltage	A9	0.8 RD/WH	1240	Battery Positive Voltage
A10	0.5 L-BU	1320	CHMSL Supply Voltage	A10	0.5 L-BU	1320	CHMSL Supply Voltage
A11	0.5 WH	17	Stop Lamp Switch Signal	A11	0.5 WH	17	Stop Lamp Switch Signal
A12	0.8 L-GN	24	Backup Lamp Supply Voltage	A12	0.8 L-GN	24	Backup Lamp Supply Voltage
			Courtesy Lamp				Courtesy Lamp

2008 Buick Lucerne CX

2008 ELECTRICAL Wiring Systems & Power Management - Lucerne

A13	0.5 GY/BK	690	Relay Control	A13	0.8 GY/BK	690	Relay Control
A14	0.35 D-GN/L-BU	170	Power Window Master Switch Right Rear Up Signal	A14	0.35 D-GN/L-BU	170	Power Window Master Switch Right Rear Up Signal
A15	0.8 GY	8	Instrument Panel Lamp Supply Voltage	A15	0.8 GY	8	Instrument Panel Lamp Supply Voltage
B1	0.35 L-BU/BK	6692	Left Rear Door Lock Motor Unlock Control	B1	0.35 L-BU/BK	6692	Left Rear Door Lock Motor Unlock Control
B2	0.35 L-BU/WH	6693	Right Rear Door Lock Motor Unlock Control	B2	0.35 L-BU/WH	6693	Right Rear Door Lock Motor Unlock Control
B3	0.35 D-BU/WH	1179	Left Rear Door Open Switch Signal	B3	0.35 D-BU/WH	1179	Left Rear Door Open Switch Signal
B4	0.35 L-BU/BK	747	Left Rear Door Ajar Switch Signal	B4	0.35 BK	747	Left Rear Door Ajar Switch Signal
B5	0.35 L-GN/BK	748	Right Rear Door Ajar Switch Signal	B5	0.35 L-GN/BK	748	Right Rear Door Ajar Switch Signal
B6	-	-	Not Used	B6	-	-	Not Used
B7	0.5 L-BU/WH	1314	Left Front Turn Signal Lamp Supply Voltage	B7	0.8 L-BU/WH	1314	Left Front Turn Signal Lamp Supply Voltage
	0.5 L-BU/WH	1314	Left Front Turn Signal Lamp Supply Voltage				
B8	0.35 PU/YE	171	Power Window Master Switch Right Rear Down Signal	B8	0.35 PU/YE	171	Power Window Master Switch Right Rear Down Signal
B9	0.35 D-GN/RD	168	Power Window Master Switch Left Rear Up Signal	B9	0.35 D-GN/RD	168	Power Window Master Switch Left Rear Up Signal
B10	0.35 PK/BK	109	Hood Ajar Switch Signal	B10	0.35 PK/BK	109	Hood Ajar Switch Signal
B11	0.35 PU/OG	5531	Hood Closed Switch Signal	B11	0.35 PU/OG	5531	Hood Closed Switch Signal
B12	0.35 L-BU	1344	Trunk Release Relay Control	B12	0.35 TN/WH	1344	Trunk Release Relay Control
B13	0.35 OG/GY	744	Trunk Ajar Switch Signal	B13	0.35 OG/GY	744	Trunk Ajar Switch Signal
B14	0.35 D-BU/PK	1307	Power Window Master Switch Lockout Signal	B14	0.35 D-BU	1307	Power Window Master Switch Lockout Signal
	0.35 L-		Power Window Master Switch		0.35 L-		Power Window Master Switch

2008 Buick Lucerne CX

2008 ELECTRICAL Wiring Systems & Power Management - Lucerne

B15	GN/GY	280	Lockout Right Rear Signal	B15	GN/GY	280	Lockout Right Rear Signal
-----	-------	-----	------------------------------	-----	-------	-----	------------------------------